

ZA46JE Parts Manual

ZOOMLION INTELLIGENT ACCESS MACHINERY CO.,LTD.

Add:Tengfei Road 997, Wangcheng District, Changsha, Hunan,PRC

Zip Code:410200

E-mail:awm@zoomlion.com

Tel:400-800-0157



ZOOMLION

ZOOMLION

ZA46JE
PARTS MANUAL

2020.10 A

Foreword

Zoomlion appreciates your choice of our machine for your application. This manual must be read and understood in its entirety before operating the machine.

This manual introduces you parts assembly and significant technical specs in detail for working efficiency improving. Keep this manual properly at all times for looking up.

Do not attempt to service and repair the machine if you do not read and understand this manual. If there is any doubt, please consult local service team for troubleshooting. Zoomlion AWP Machinery Company does not take the consequence of wrong maintenance.

This manual should be considered a permanent part of your machine and should remain with the machine at all times. When transferring this machine, be sure to transfer this manual to the transferee.

The content is under intellectual property protection, permission is required for a copy or other application.

There might be some tiny differences in details between your machine and the upgraded one due to the continuous improving. For clarification, questions, or additional information regarding any portions of this manual, Contact Zoomlion AWP Machinery

Our company reserves the right to modify this manual as technical improvement without notice.

Thank you for your trust and support for Zoomlion products!

Zoomlion Intelligent Access Machinery Co.,Ltd.

Contents

Foreword	I
Contents	II
Chapter 1 Work Platform	1-1
Work Platform 00773400120000000	1-1
Chapter 2 Boom	2-1
Jib 00773400210000000	2-1
Upper Boom Assembly 00773400310000000	2-3
Chain System 00773400710000000	2-7
Tower Boom Assembly 00773400410000000	2-9
Chapter 3 Turntable	3-1
Turntable 00773400820000000	3-1
Hood 00773401110000000	3-5
Counterweight 00773401010000000	3-7
Slewing Mechanism 00773400900000000	3-9
Chapter 4 Chassis	4-1
Chassis 00773402820000000	4-1
Chapter 5 Power System	5-1
Power System Assembly 00773407110000000	5-1
Chapter 6 Hydraulic System	6-1
Hydraulic Tank Assembly 00773405210200000	6-1
Hydraulic Pump Assembly 00773405210400000.....	6-3
Steering Valve Assembly 00773405210600000.....	6-5
Centre Revolving Joint Assembly 00773405210800000	6-7
High Pressure Filter Assembly 00773405211000000	6-9
Platform Select Valve Assembly 00773405211200000	6-11
Main Valve Assembly 00773405211600000.....	6-13
Telescopic Select Valve Assembly 00773405212400000	6-15
Balance Valve Assembly 00773405212800000	6-17
Balance Valve Assembly 00773405213000000	6-19

Contents

Balance Valve Assembly 0077340521320000	6-21
Balance Valve Assembly 0077340521340000	6-23
Balance Valve Assembly 0077340521360000	6-25
Balance Valve Assembly 0077340521380000	6-27
Hydraulic System Piping Diagram 0077340521400000	6-29
Chapter 7 Electrical System.....	7-1
Turntable Electrical Control Box Assembly 00773406230220000.....	7-1
Platform Electrical Box Assembly 00773406230210000	7-3
Turntable Cable 00773406230410000	7-5
Boom Wires 00773406230430000.....	7-7
Chassis Wires 00773406230420000	7-9
Platform Wires 00773406230440000/ Chain Wires Change 00773406230610000.....	7-11

ZOOMLION

Parts Manual

Section 1 Work Platform



Work Platform 0077340012000000

WORK
PLATFORM

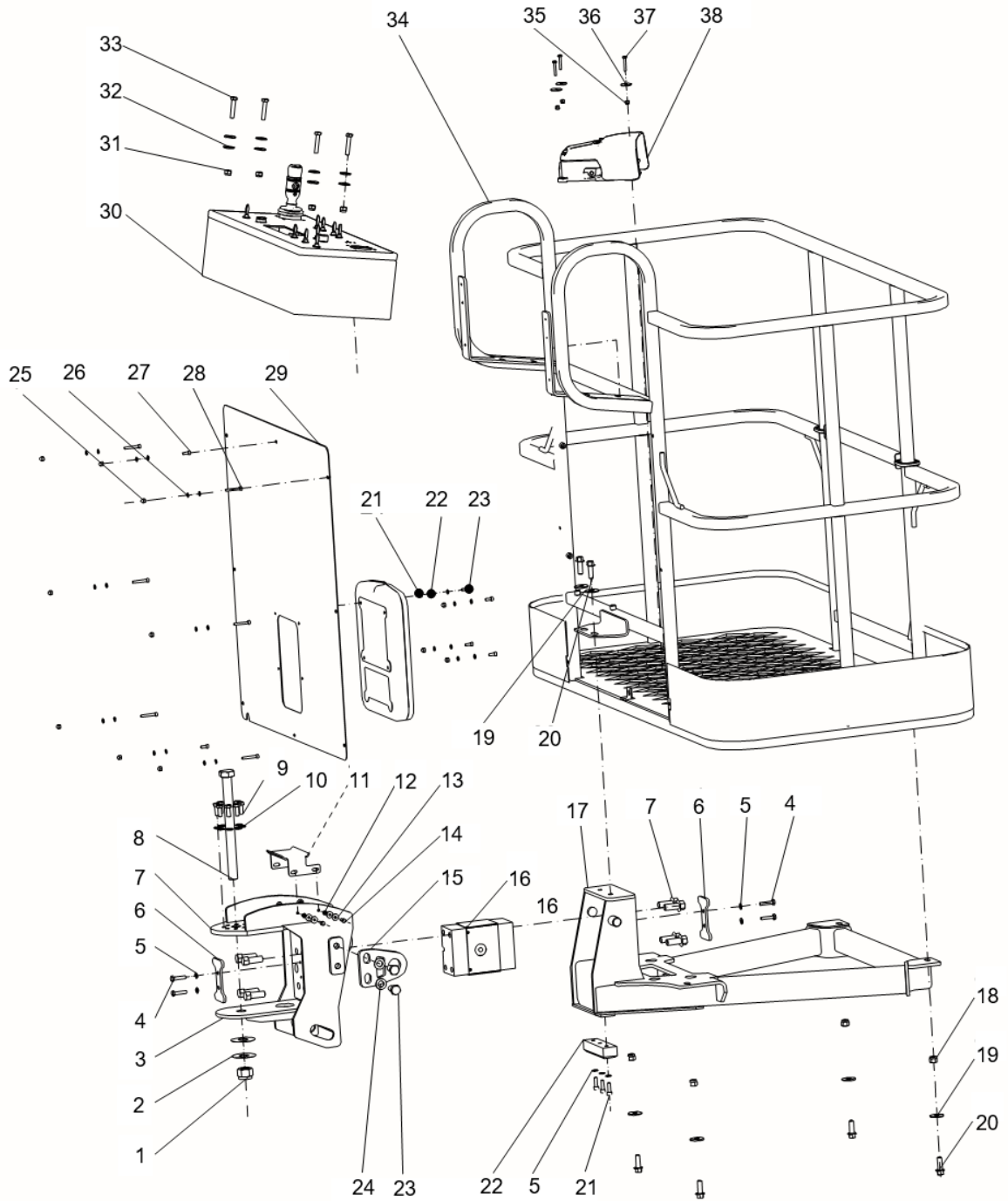

Work Platform 0077340012000000

NO.	Material No.	Item and Spec	Qty	Remark
1	1040201111	Nut M24-10	1	GB/T889
2	00773400100401030	Adjusting shim	2	
3	00773400110410000	Transition seat	1	
4	1040004619	Bolt M8×35-8.8	4	GB/T5783
5	1040301515	Gasket 8-200HV	4	GB/T97.1
6	00773400100401020	Pressing plate	2	
7	1040004654	Bolt M16×1.5×40-10.9	8	GB/T5787
8	1040004505	Bolt M24×280-10.9	1	GB/T5782
9	1040004033	Bolt M10×25-10.9	8	GB/T5783
10	1040302489	Gasket 10-200HV	8	GB/T97.1
11	00773400110401050	Plate	1	
12	1040201865	Nut M6-8	4	GB/T6170
13	1040300735	Gasket 6-200HV	8	GB/T96.1
14	1040001631	Bolt M6×20-A2-70	4	GB/T5783
15	00773400110401010	Anti-drop plateII	2	
16	1021404016	Load cell	1	
17	007734001004 0	Tray weldment	1	
18	1040200507	Nut M12-8	4	GB/T889.1
19	1040302821	Gasket 12-200HV	6	GB/T96.1
20	1040004556	Bolt M12×35-8.8	6	GB/T16674.1
21	1040103112	Screw M8×25-8.8	3	GB/T70.1
22	00773400100401040	Cushion block	1	
23	1040003324	Bolt M16×30-10.9-DKL	4	GB/T5783
24	1040302492	Gasket 16-200HV	4	GB/T97.1
25	1040201902	Nut M6-6	12	GB/T802
26	1040300771	Gasket 6-200HV	24	GB/T97.1
27	1040102774	Screw M6×15-8.8	6	GB/T70.1
28	1040102773	Screw M6×40-8.8	6	GB/T70.1
29	00773400100201010	Dam-boardI	1	
30	00773406 10000	Platform electrical control box assembly	1	
31	1040200504	Nut M10-8	4	GB/T889.1
32	1040302512	Gasket 10-200HV	8	GB/T96.1
33	1040004509	Bolt M10×50-8.8	4	GB/T5783

Work Platform 0077340012000000

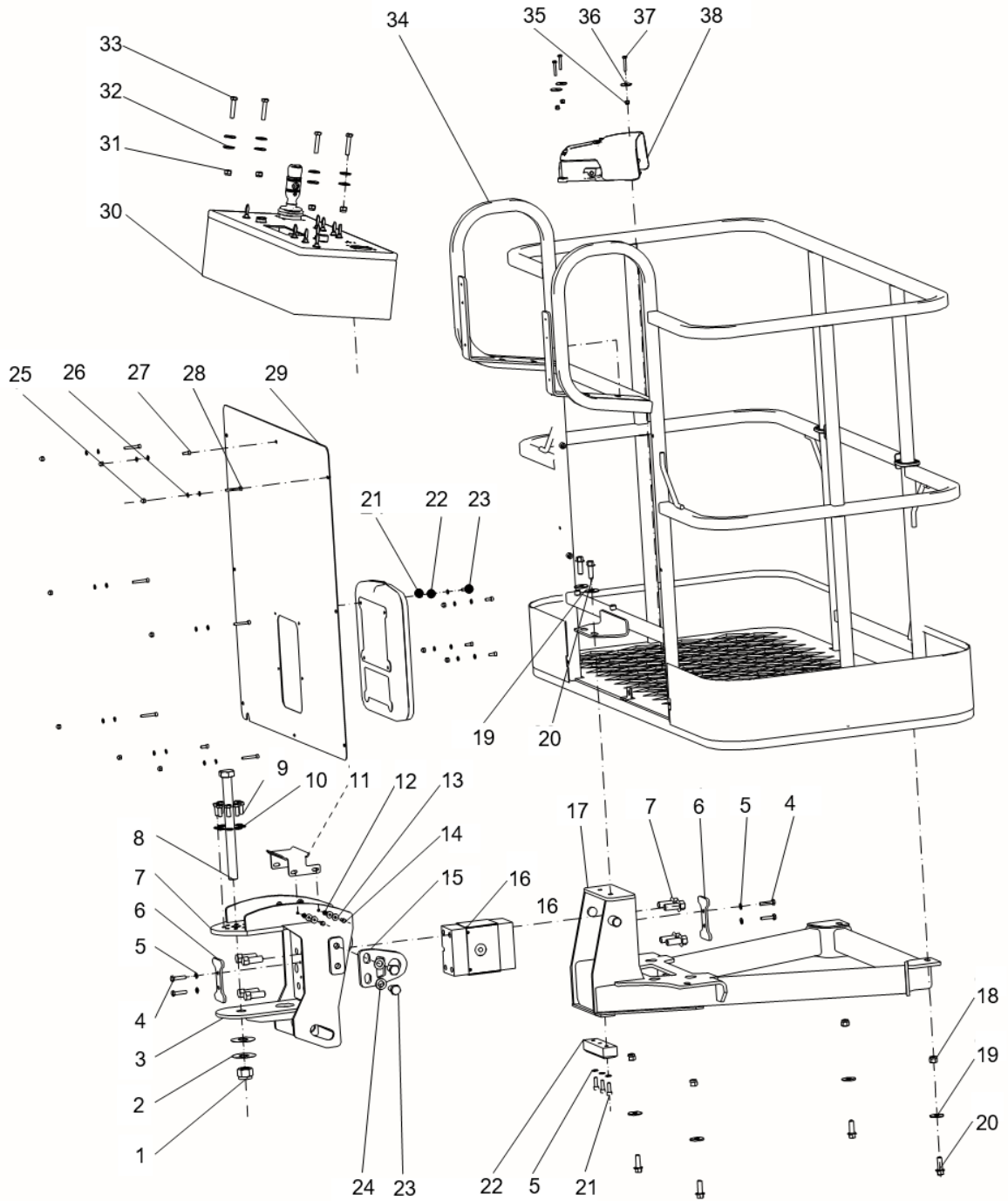

Work Platform 00773400120000000

NO.	Material No.	Item and Spec	Qty	Remark
34	00773400120210000	Platform weldment	1	
35	1040201896	Nut M6-8	3	GB/T889.1
36	00773406300201010	Spacer	3	
37	1040004553	Bolt M6×35-8.8	3	GB/T5783
38	1020521022	Foot switch	1	

ZOOMLION

Parts Manual

Section 2 Boom



Jib 0077340021000000

BOOM

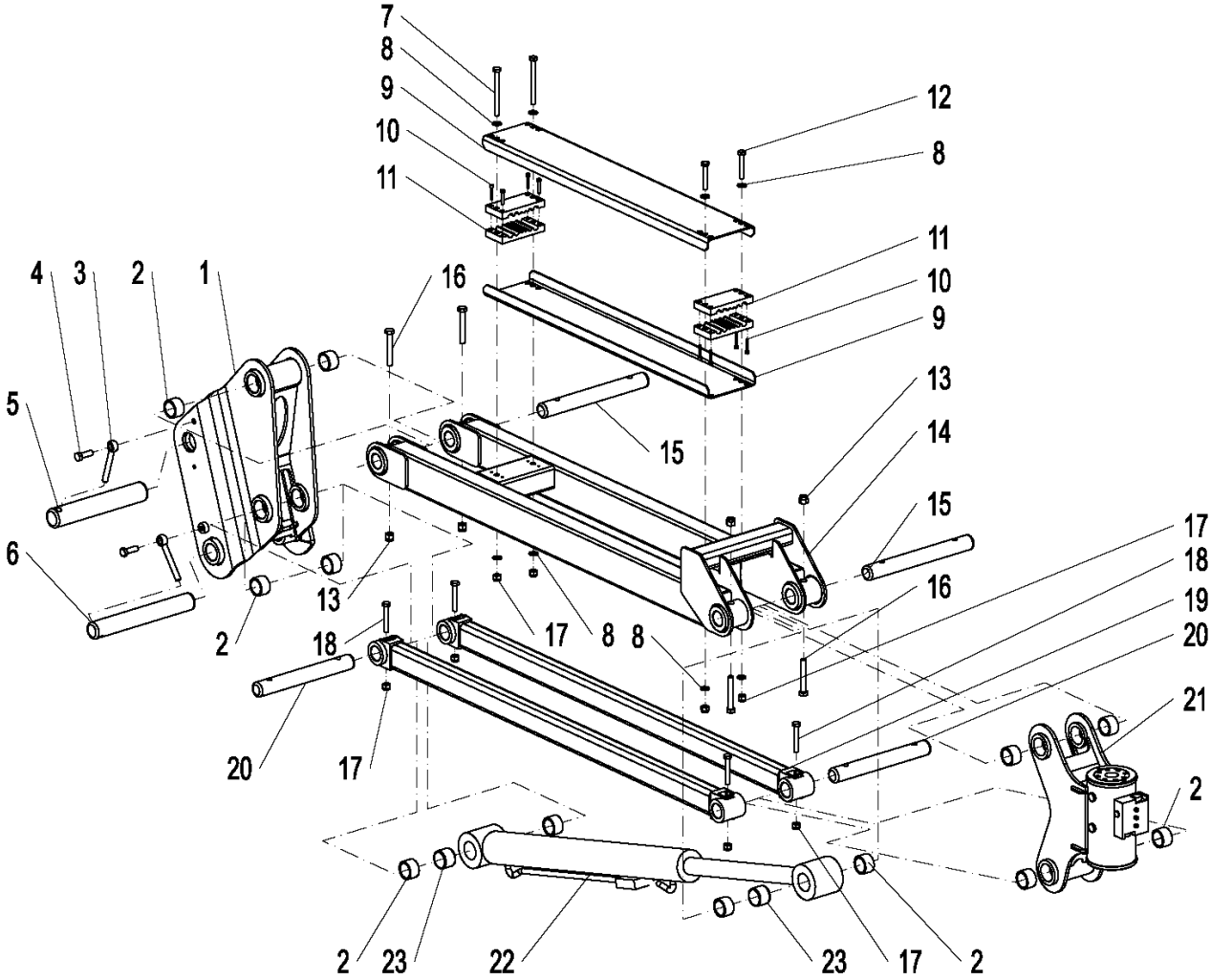

Jib 0077340021000000

NO.	Material No.	Item and Spec	Qty	Remark
1	00773400210200000	Support	1	
2	00773400200001010	Bearing	12	
3	00773400200001070	Stop pin	2	
4	1040002437	Bolt M12×35-8.8	2	GB/T5783
5	00773400200001060	Pin	1	
6	00773400200001050	Pin	1	
7	1040004658	Bolt M10×110-8.8	2	GB/T5782
8	1040302489	Gasket 10-200HV	8	GB/T97.1
9	00773400200001080	Pipeline backplate	2	
10	1040103106	Screw M5×30-8.8	8	GB/T70.1
11	00773400200001090	Pipeline neck	4	
12	1040004535	Bolt M10×60-8.8	2	GB/T5782
13	1040200507	Nut M12-8	4	GB/T889.1
14	00773400200400000	Linkage	1	
15	00773400200001030	Pin	2	
16	1040004657	Bolt M12×80-8.8	4	GB/T5782
17	1040200504	Nut M10-8	8	GB/T889.1
18	1040004656	Bolt M10×65-8.8	4	GB/T5782
19	00773400200600000	Linkage	2	
20	00773400200001040	Pin	2	
21	1010201471	Rotary actuator	1	L20-08-180
22	00773400201000000	Jib cylinder	1	
23	00773400200001100	Bushing	2	

Upper Boom Assembly 0077340031000000

BOOM

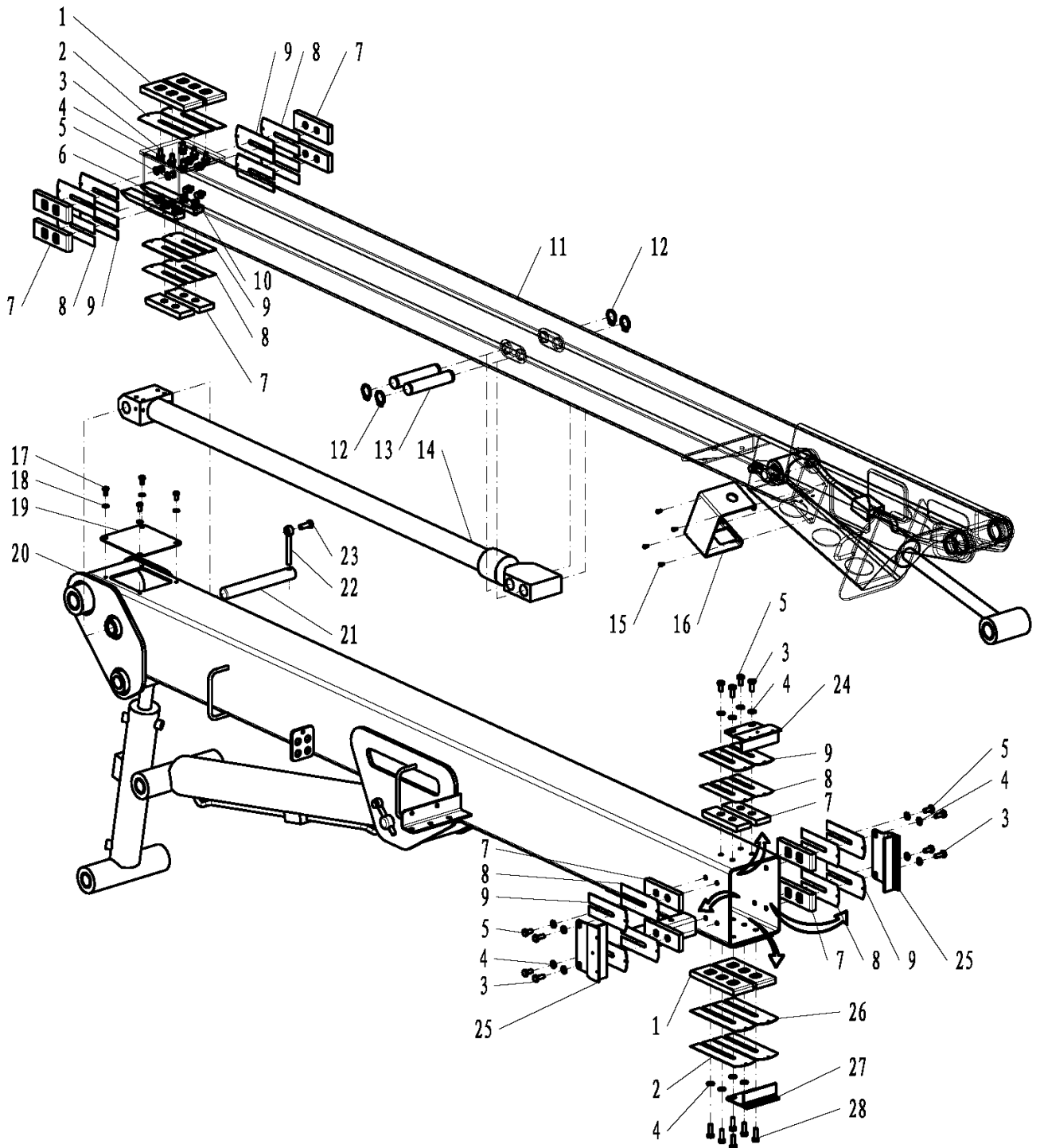

Upper Boom Assembly 00773400310000000

NO.	Material No.	Item and Spec	Qty	Remark
1	00771600301630000	Slider	4	
2	00771400301401020	Adjusting shim Tp1	4	
3	1040002434	Bolt M10×25-8.8	12	GB/T5783
4	1040302489	Gasket 10-200HV	34	GB/T97.1
5	1040002433	Bolt M10×20-8.8	14	GB/T5783
6	00773400310001240	Travel switch contact plate	2	
7	00773700302800000	Slider	12	
8	00773400300001150	Adjusting shim VITp0.5	12	
9	00773400300001130	Adjusting shim IVTp2	12	
10	1040002435	Bolt M10×35-8.8	4	GB/T5783
11	00773400310400000	Telescopic boom	1	
12	1040302506	Check ring 32	4	JB/ZQ4342
13	00773400310001020	Pin	2	
14	00773400311600000	Telescopic cylinder	1	
15	1040103038	Screw M5×10	4	GB/T70.1
16	00773400300001280	Platform select valve cover	1	
17	1040004517	Bolt M8×16-8.8	4	GB/T5783
18	1040301515	Gasket 8-200HV	4	GB/T97.1
19	00773400310001200	Small cover plate	1	
20	00773400310200000	Base boom	1	
21	00773400310001050	Pin V	1	
22	00773400200001070	Stop pin	4	
23	1040004511	Bolt M12×30-8.8	4	GB/T5783
24	00773400311200000	Dust-proof brush	1	
25	00773400311000000	Side brush	2	
26	00771400301401010	Adjusting shimTp2	2	
27	00773400312000000	Dust-proof brush	1	
28	1040004565	Bolt M10×30-8.8	6	GB/T5783

Upper Boom Assembly 0077340031000000

BOOM

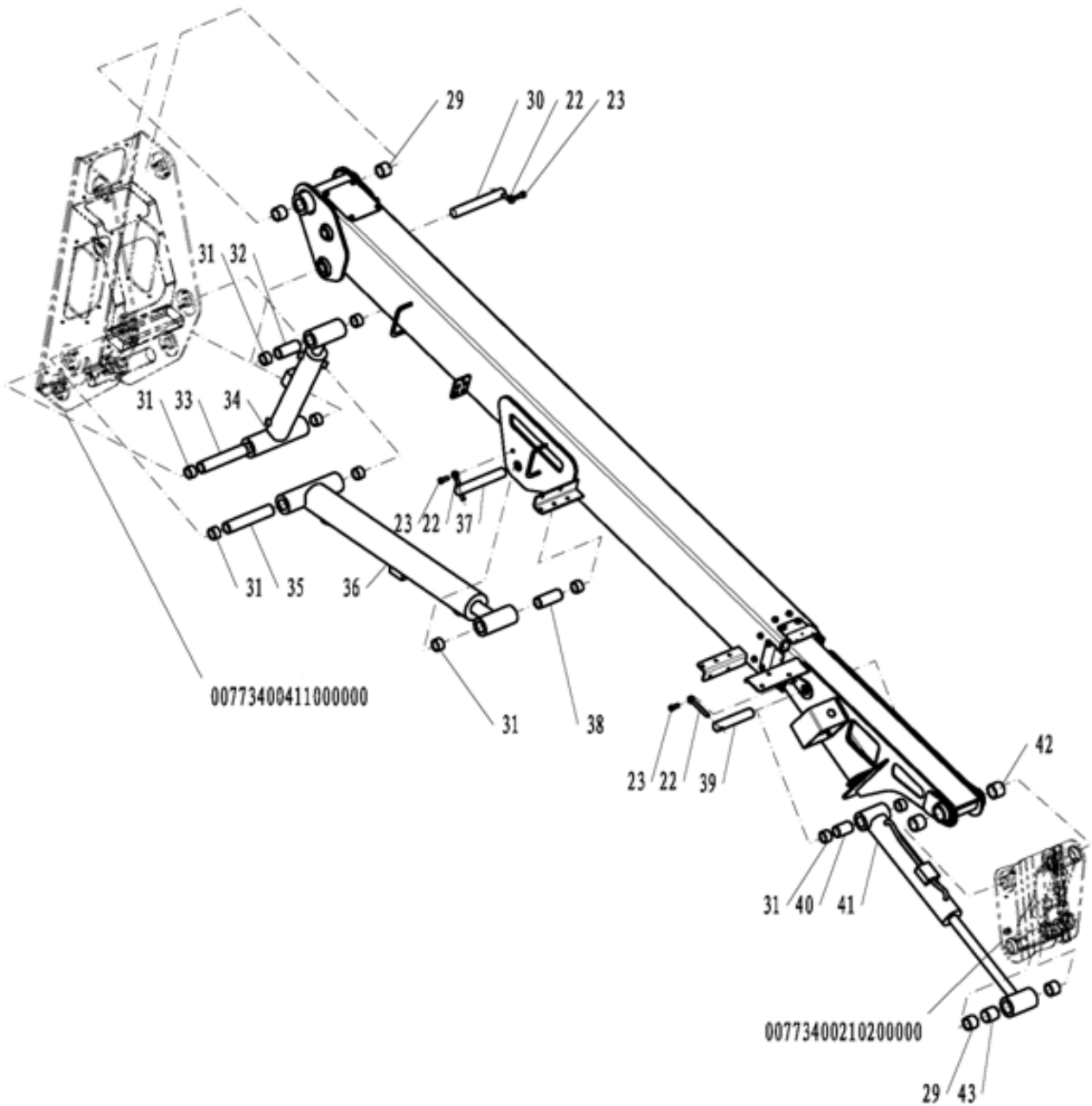

Upper Boom Assembly 00773400310000000

NO.	Material No.	Item and Spec	Qty	Remark
29	00773400300001210	Bearing	4	
30	00773400310001130	Pin	1	
31	00773400200001010	Bearing	10	
32	00773400310001090	Bushing IV	1	
33	00773400310001100	Bushing V	1	
34	00773400310600000	Leveling cylinder	1	
35	00773400310001080	Bushing III	1	
36	00773400310800000	Lifting cylinder	1	
37	00773400310001140	Pin	1	
38	00773400310001070	Bushing II	1	
39	00773400310001010	Pin	1	
40	00773400310001060	Bushing I	1	
41	00773400311400000	Leveling cylinder	1	
42	00773400300001050	Bearing	2	
43	00773400300001060	Bushing	1	

Chain System 0077340071000000

BOOM

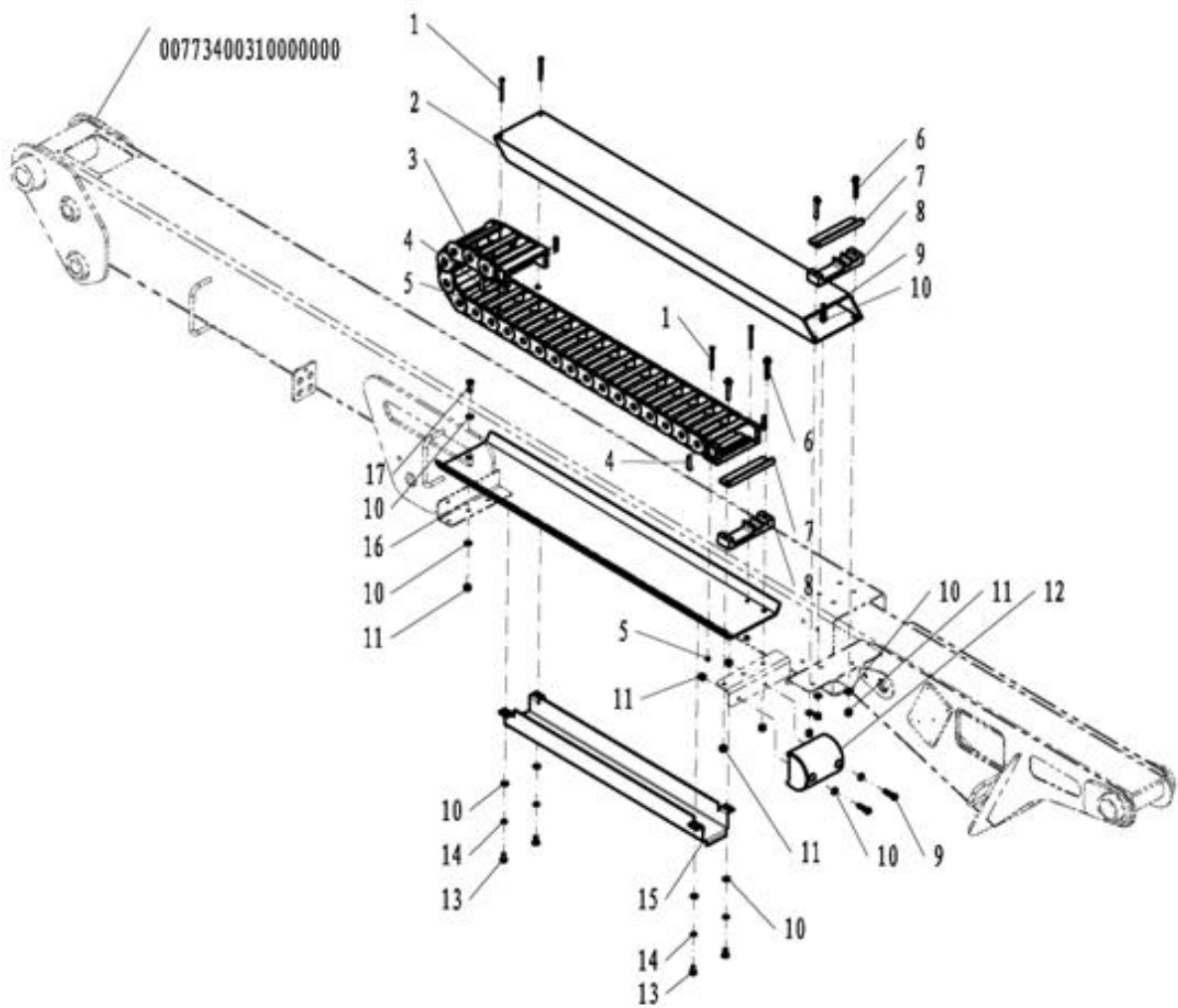

Chain System 0077340071000000

NO.	Material No.	Item and Spec	Qty	Remark
1	1040004670	Bolt M5×60-8.8	4	GB/T5782
2	00773400710001010	Rectangle tube	1	
3	00773400700001080	Chain mechanism	1	
3A	1109900992	Cable cross-bar 27000.12	20	
3B	1109900994	Cable shim 35.1	50	
3C	1109900996	links section body 2700.12.075.0	20	
3D	1109900997	Connector link hole 26101.12.C.1	1	
3E	1109900998	Connector link pin 26101.12.C.2	1	
4	00773400700001060	Pipe-jacking	4	
5	1040200574	Nut M5-8	4	GB/T6170
6	1040004557	Bolt M8×50-8.8	4	GB/T16674.1
7	00773400700001050	Bending plate	2	
8	00773400700001020	Hose holder	2	
9	1040102737	Screw M8×30-8.8	3	GB/T70.1
10	1040301515	Gasket 8-200HV	12	GB/T97.1
11	1040200503	Nut M8-8	8	GB/T889.1
12	00773400700001030	Nylon block	1	
13	1040004517	Bolt M8×16-8.8	4	GB/T5783
14	1040301510	Gasket 8	4	GB/T93
15	00773400700001040	Tube slot	1	
16	00773400700400000	Tray	1	
17	1040004519	Bolt M8×25-8.8	1	GB/T5783

Tower Boom Assembly 0077340041000000

BOOM

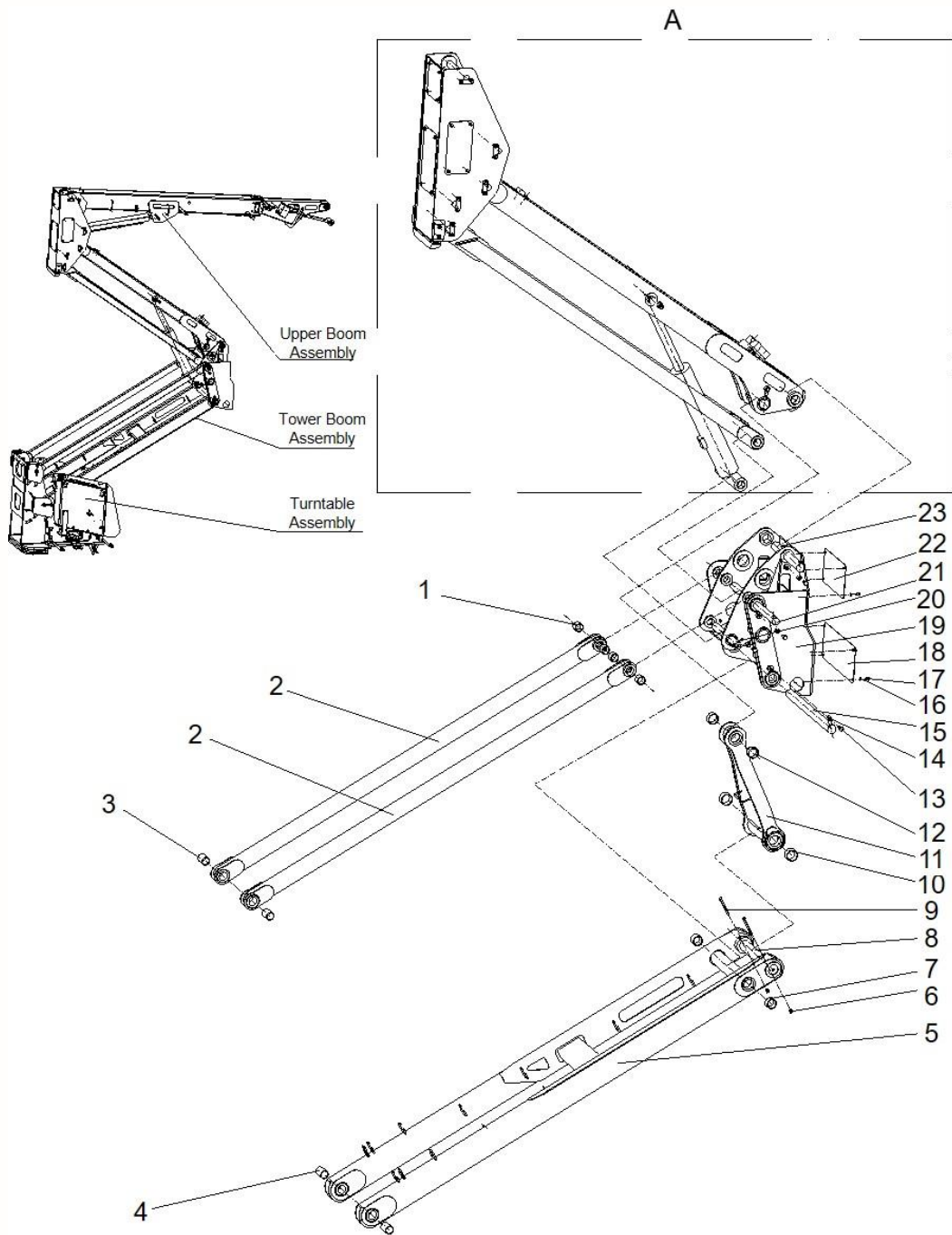

Tower Boom Assembly 00773400410000000

NO.	Material No.	Item and Spec	Qty	Remark
1	00773400300001050	Bearing	12	
2	00773400410400000	Linkage II	2	
3	00773400410001150	Bearing	4	
4	00773400410001140	Bearing	2	
5	00773400410200000	Linkage I	1	
6	1040200507	Nut M12-8	2	GB/T889.1
7	00773400400001130	Bearing	4	
8	00773400410001120	PinA9	1	
9	1040005888	Bolt M12×120-10.9	2	GB/T5782
10	00771400600001070	Self-lubricating Bearing	2	
11	00773400411400000	Pull rod	1	
12	0077340040001130	Bearing	2	
13	1040004570	Bolt M16×30-8.8	6	GB/T5783
14	0077340040001250	Stop pin	5	
15	00773400410001100	Pin A7	1	
16	1040302489	Gasket 10-200HV	48	GB/T97.1
17	1040004646	Bolt M10×15-8.8	24	GB/T5783
18	00773400410001220	Sealing plate III	1	
19	00773400411200000	Upright	1	
20	00773400410001080	Pin A5	1	
21	00773400410001090	Pin A6	1	
22	00773400410001210	Sealing plate II	1	
23	00773400410001070	Pin A4	1	

Tower Boom Assembly 0077340041000000

BOOM

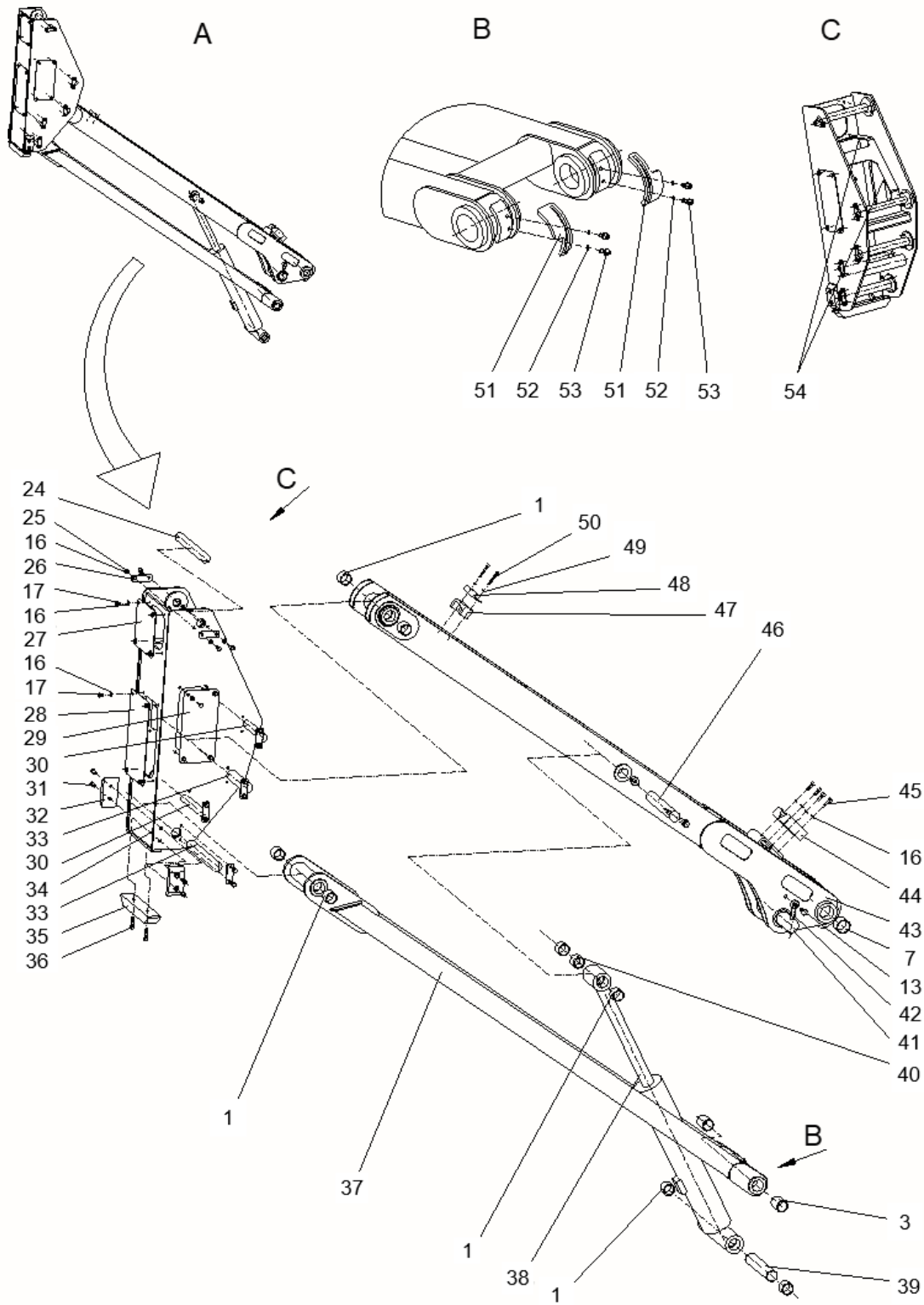

Tower Boom Assembly 00773400410000000

NO.	Material No.	Item and Spec	Qty	Remark
24	00773400410001060	Pin A3	1	
25	1040002433	Bolt M10×20-8.8	20	GB/T5783
26	00773400410001180	Sam-board	10	
27	00773400400001300	Small cover plate	1	
28	00773400410001200	Sealing plate I	1	
29	00773400410001290	Sealing plate IV	2	
30	00773400410001170	PinA10	2	
31	1040103140	Screw M12×25-8.8	4	GB/T70.1
32	00773400410001190	Slider	2	
33	00773400410001040	Pin A1	2	
34	00773400411000000	Upright	1	
35	00773400410001020	Upright guide block	1	
36	1040101494	Screw M12×40-8.8	2	GB/T70.1
37	00773400410600000	Linkage III	1	
38	00773400411600000	Lifting cylinder	1	
39	00773400410001270	Bushing	1	
40	00773400410001260	Bushing	1	
41	00773400410001110	Pin A8	1	
42	00773400410001230	Stop pin	1	
43	00773400410800000	Linkage IV		
44	00773400410001010	Buffer plate	2	
45	1040101995	Screw M10×30-8.8	4	GB/T70.1
46	00773400410001160	Pin	1	
47	00773400410001300	Clip	1	
48	00773400410001310	Pressing plate	1	
49	1040301515	Gasket 8-200HV	2	GB/T97.1
50	1040102739	Screw M8×60-8.8	2	GB/T70.1
51	00773400410001280	Mounting plate	2	
52	1040300771	Gasket 6-200HV	4	GB/T97.1
53	1040102774	Screw M6×15-8.8	4	GB/T97.1
54	1990300400	U type tape	2	

ZOOMLION

Parts Manual

Section 3 Turntable



Turntable 0077340082000000

回转平台

TURNTABLE

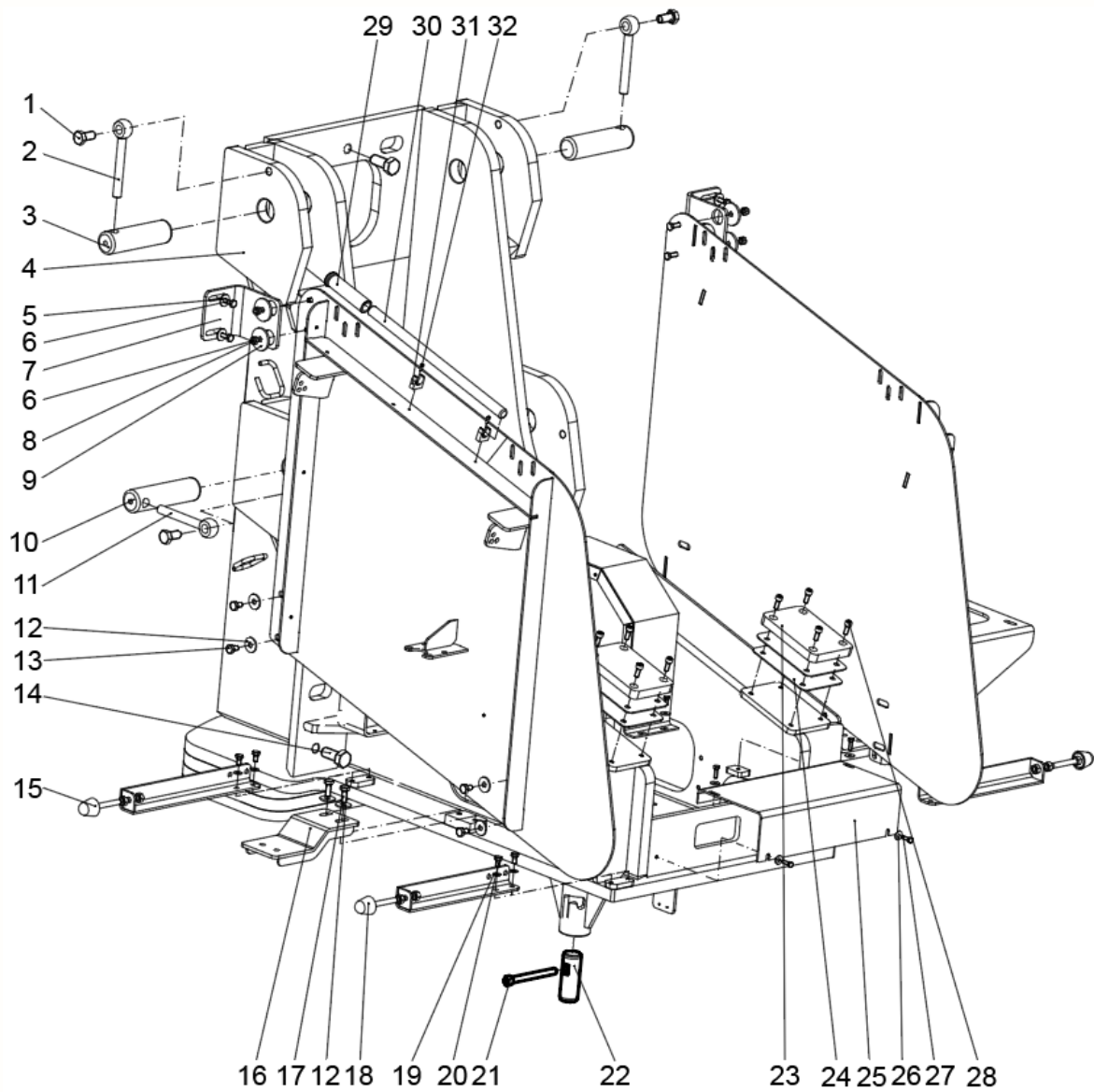

Turntable 0077340082000000

NO.	Material No.	Item and Spec	Qty	Remark
1	1040004570	Bolt M16×30-8.8	4	GB/T5783
2	00773400410001230	Stop pin	2	
3	00773400820001070	Axle I	2	
4	00773400820200000	Turntable structure	1	
5	1040302480	Gasket 8-200HV	8	GB/T96.1
6	1040004520	Bolt M8×30-8.8	8	GB/T5783
7	00773400820001120	Bending plate	2	
8	1040200503	Nut M8-8	4	GB/T889.1
9	00773400820001130	Gasket	4	
10	00773400820001080	Axle II	2	
11	00773400410001230	Stop pin	2	
12	1040302512	Gasket 10-200HV	12	GB/T96.1
13	1040004646	Bolt M10×15-8.8	8	GB/T5783
14	1040004499	Bolt M20×45-8.8	3	GB/T5783
15	00773400821200000	Door stop mounting II	2	
16	00773400820800000	Support	2	
17	1040002434	Bolt M10×25-8.8	4	GB/T5783
18	00773400821000000	Door stop mounting I	2	
19	1040301515	Gasket 8-200HV	8	GB/T97.1
20	1040004590	Bolt M8×14-8.8	8	GB/T5783
21	1040100714	Screw M12×130-8.8	1	GB/T70.1
22	00773400820001010	Lock pin	1	
23	00773400820001040	Cushion pad	2	
24	00773400820001090	Adjusting pad	4	
25	00773400820001100	Front plate	1	
26	1040300735	Gasket 6-200HV	10	GB/T96.1
27	1040001631	Bolt M6×20-8.8	4	GB/T5783
28	1040003252	Hexagon socket head cap screw M8×20-12.9	8	GB/T70.1
29	00773700810801010	Handle sleeve	1	
30	00773700810801020	Rod	1	
31	00773700810001050	Shelves	2	
32	1040101846	Screw M4×10-8.8	2	GB/T70.1

Turntable 0077340082000000

回转平台

TURNTABLE

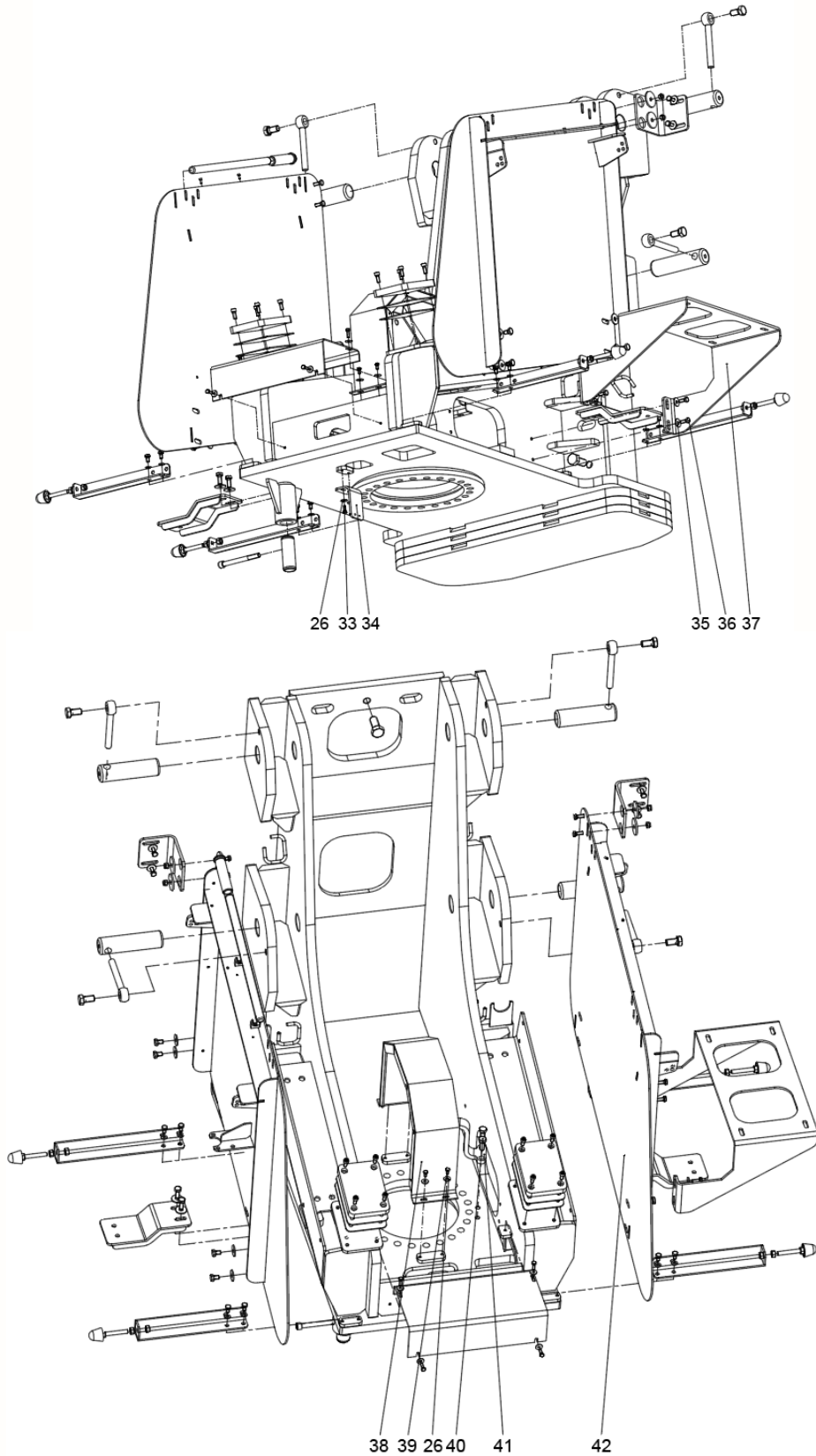

Turntable 0077340082000000

NO.	Material No.	Item and Spec	Qty	Remark
33	1040002555	Bolt M6×16-70	2	GB/T5783
34	00773400820001030	Rotary limit switch	1	GB/T96.1
35	1040302480	Gasket 8-200HV	8	GB/T96.1
36	1040004518	Bolt M8×20-8.8	4	GB/T5783
37	00773400820001020	Electric control cabinet seat	1	
38	00773400820600000	Slip ring cover	1	
39	1040002738	Bolt M6×12-8.8	4	GB/T5783
40	1040004511	Bolt M12×30-8.8	2	GB/T5783
41	00773400821800000	Support	1	

Hood 0077340111000000

回转斗盖

TURNABLE

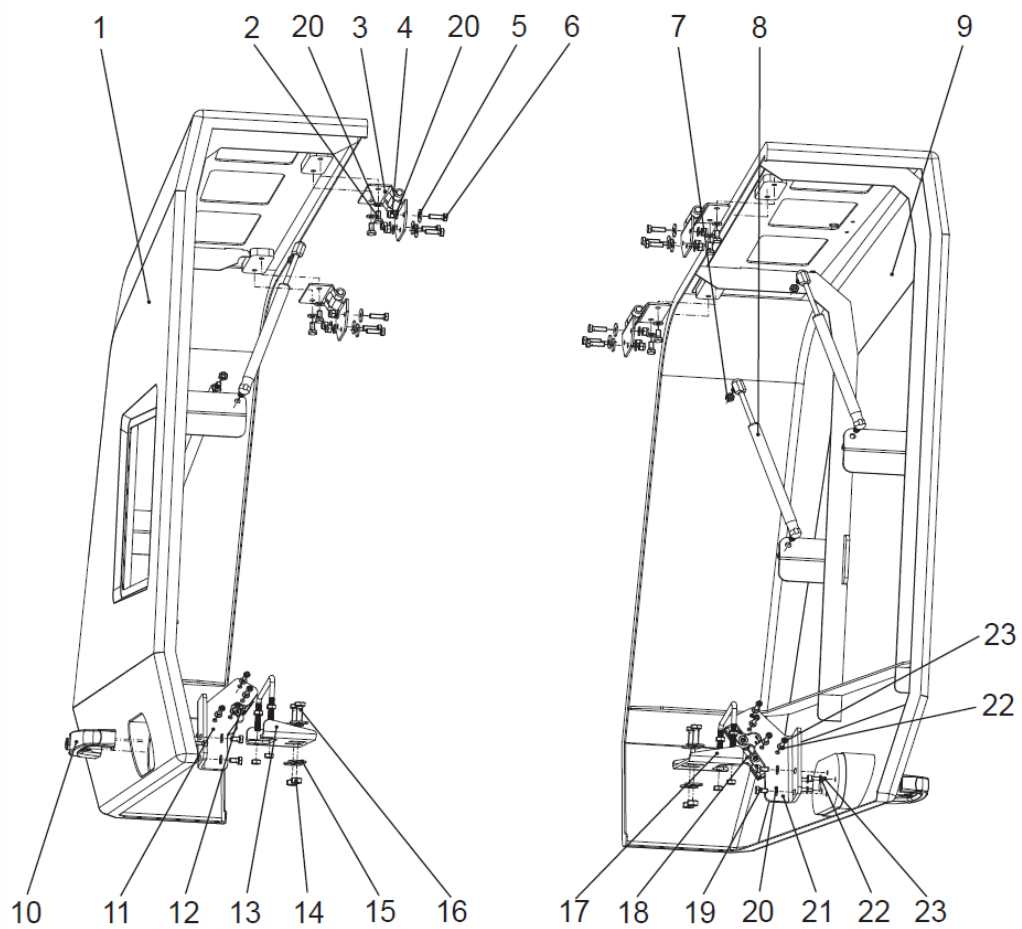

Hood 0077340111000000

NO.	Material No.	Item and Spec	Qty	Remark
1	00773401110600000	Hood weldment	1	
2	1040004517	Bolt M8×16-8.8	8	GB/T5783
3	1101000089	Hinge	4	
4	1040200503	Nut M8-8	12	GB/T889.1
5	1040302480	Gasket 8-200HV	12	GB/T96.1
6	1040004519	Bolt M8×25-8.8	12	GB/T5783
7	1040201089	Nut M8-8	16	GB/T6170
8	1110100355	Gas spring	4	
9	00773401110800000	Hood weldment	1	
10	1100700163	Door knob	2	
11	00773401110001030	Lock seat	1	
12	1109900778	Door lock	1	
13	00773401110400000	Lock seat	1	
14	1040200113	Nut M10-8	4	GB/T6170
15	1040302512	Gasket 10-200HV	8	GB/T96.1
16	1040004565	Bolt M10×30-8.8	4	GB/T5783
17	00773401110200000	Lock seat	1	
18	1109900779	Door lock	1	
19	1040004590	Bolt M8×14-8.8	4	GB/T5783
20	1040301515	Gasket 8-200HV	24	GB/T97.1
21	00773401110001010	Lock seat	1	
22	1040300771	Gasket 6-200HV	14	GB/T97.1
23	1040100105	Screw M6×25-8.8	14	GB/T70.1

Counterweight 0077340101000000

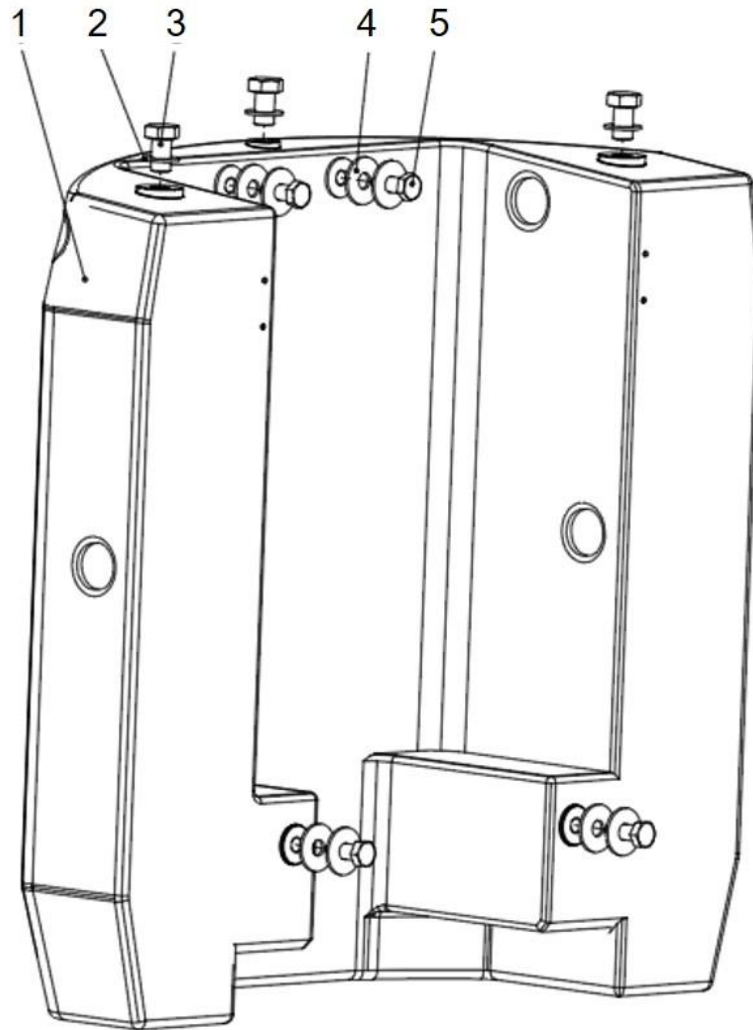

TURNABLE

Counterweight 00773401010000000

NO.	Material No.	Item and Spec	Qty	Remark
1	00773401010001010	Counterweight block	1	
2	1040301513	Gasket 30-200HV	3	GB/T5783
3	1040004500	Bolt M30×50-8.8	3	GB/T5783
4	1040302483	Gasket 24-200HV	8	GB/T96.1
5	1040004613	Bolt M24×60-10.9	4	GB/T5782

Slewing Mechanism 0077340090000000

回转支承

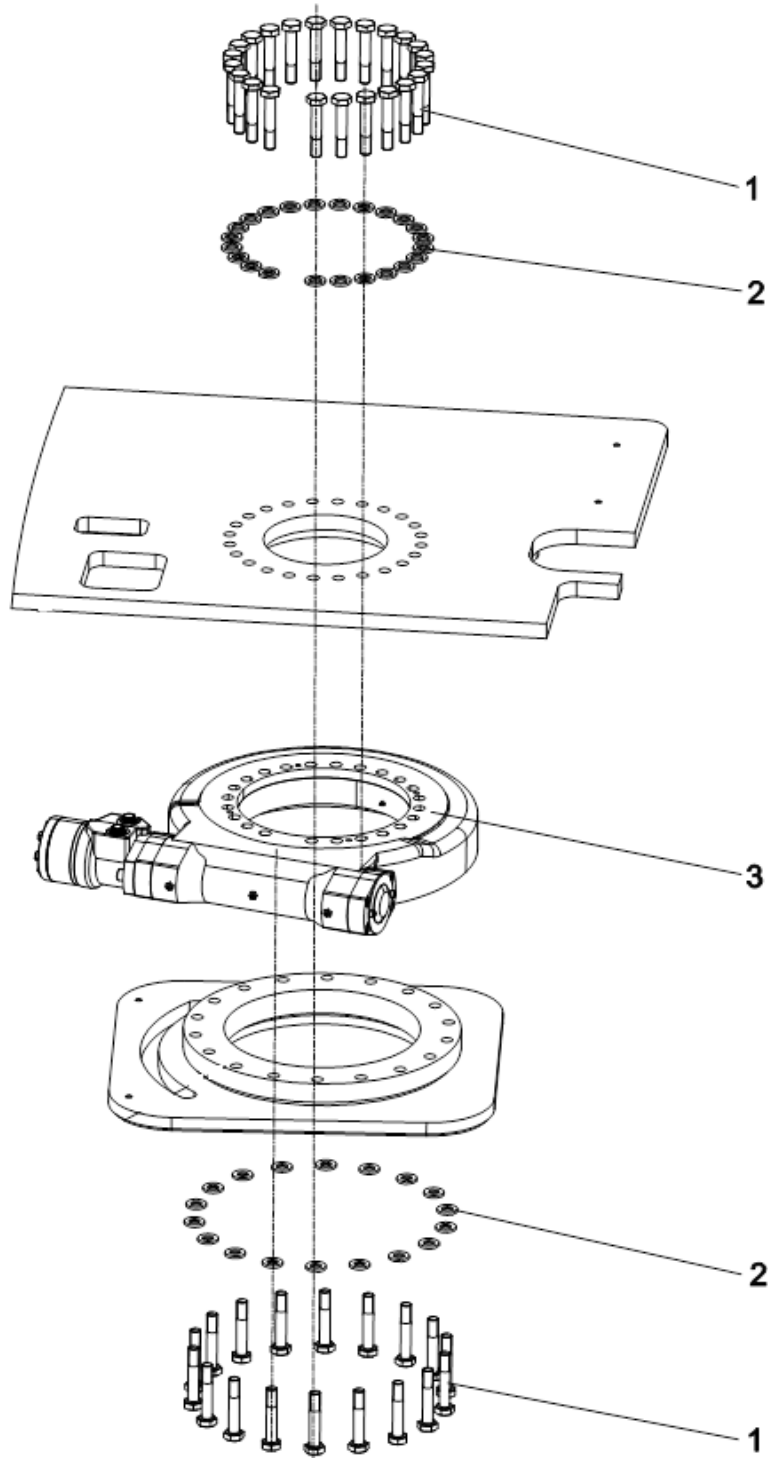

TURNABLE

Slewing Mechanism 00773400900000000

NO.	Material No.	Item and Spec	Qty	Remark
1	1040000698	Bolt M16×90-10.9	41	GB/T1228
2	1040300186	Gasket 16	41	GB/T1230
3	1030202173	Slewing reducer	1	

ZOOMLION

Parts Manual

Section 4 Chassis



Chassis 0077340282000000

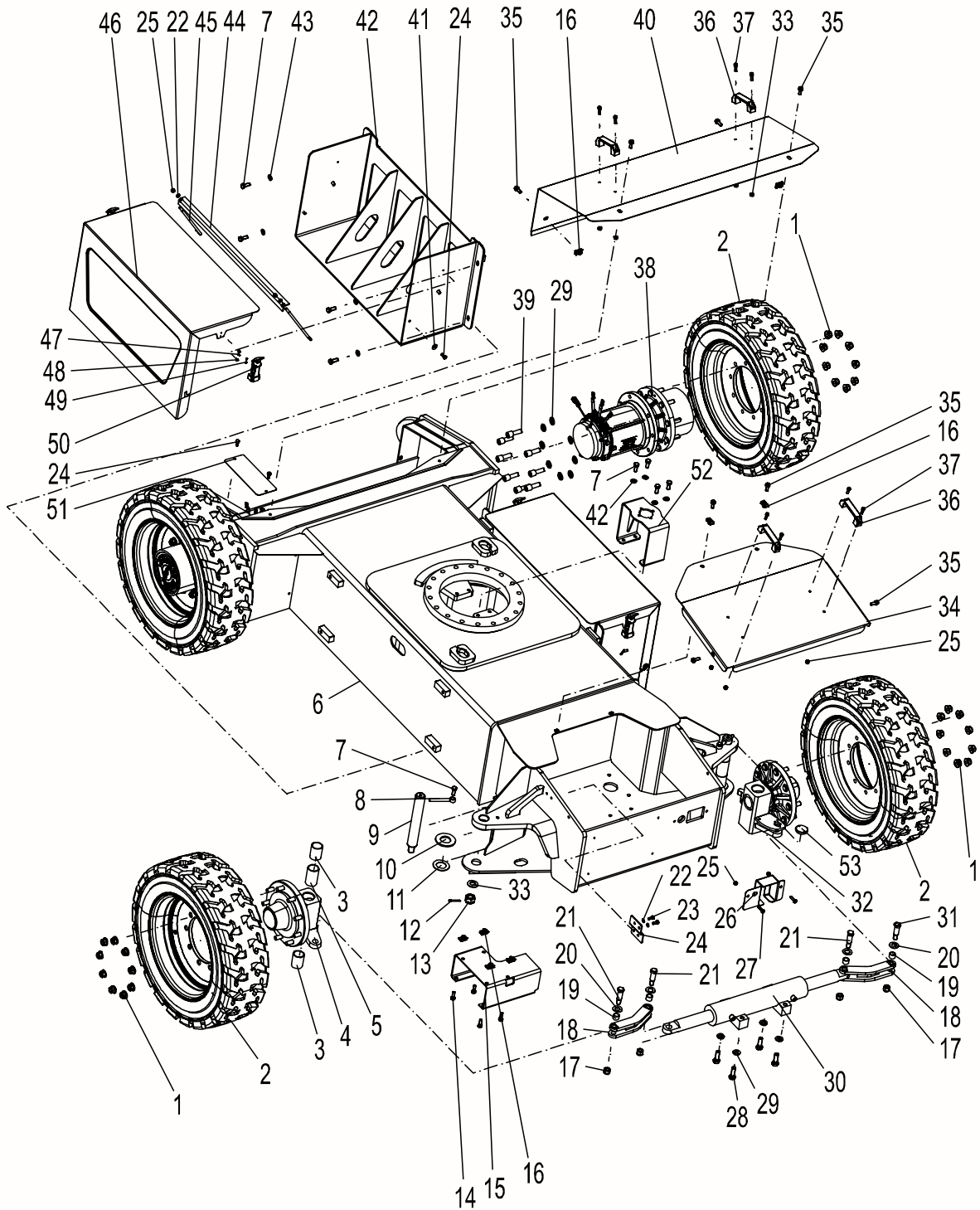

Chassis 0077340282000000

NO.	Material No.	Item and Spec	Qty	Remark
1	1040202296	Nut 5/8-18UNF-10 (Spiralock)	36	ANSIB18.2.2
2	1030800654	Tire	4	IN240/55D17.5
3	00773402820001110	Bearing	4	
4	00773402820800000	Hub assembly	1	
5	00773402820001120	Bushing	2	
6	00773402820400000	Frame weldment	1	
7	1040004653	Bolt M12×30-10.9	14	GB/T5783
8	00773400200001070	Stop pin	2	
9	00773402820001070	Pin	2	
10	00773402800001110	Spacer	2	
11	00773402800001270	Gasket	2	
12	1040500394	Cotter 5×40	2	GB/T91
13	1040202280	Nut M24-05-DKL	2	GB/T6181
14	1040000090	Bolt M10×30-8.8	4	GB/T5783
15	00773402820001050	Support	1	
16	1040201860	Nut M10	8	QC/T608
17	1040200161	Nut M16-8	4	GB/T889
18	00773402822000000	Pulling rod I	2	
19	00773402800001260	Bearing	4	
20	00773402820001030	Pulling rod spacer	4	
21	00773402820001080	Pin	3	
22	1040301515	Gasket 8-200HV	6	GB/T97.1
22	1040004518	Bolt M8×20-8.8	10	GB/T5783
23	00773402820001020	Support	1	
24	1040200503	Nut M8-8	12	GB/T889.1
25	00773402820001090	Protect box	1	
26	1040004520	Bolt M8×30-8.8	2	GB/T5783
27	1040004496	Bolt M16×45-10.9	4	GB/T5783
28	1040302817	Gasket 16-DKL	20	GB/T1230
29	00773402821800000	Steering cylinder	1	
30	00773402820001100	Pin II	1	
31	00773402820600000	Hub assembly	1	
32	1030800654	Tire	4	IN240/55D17.5

Chassis 0077340282000000

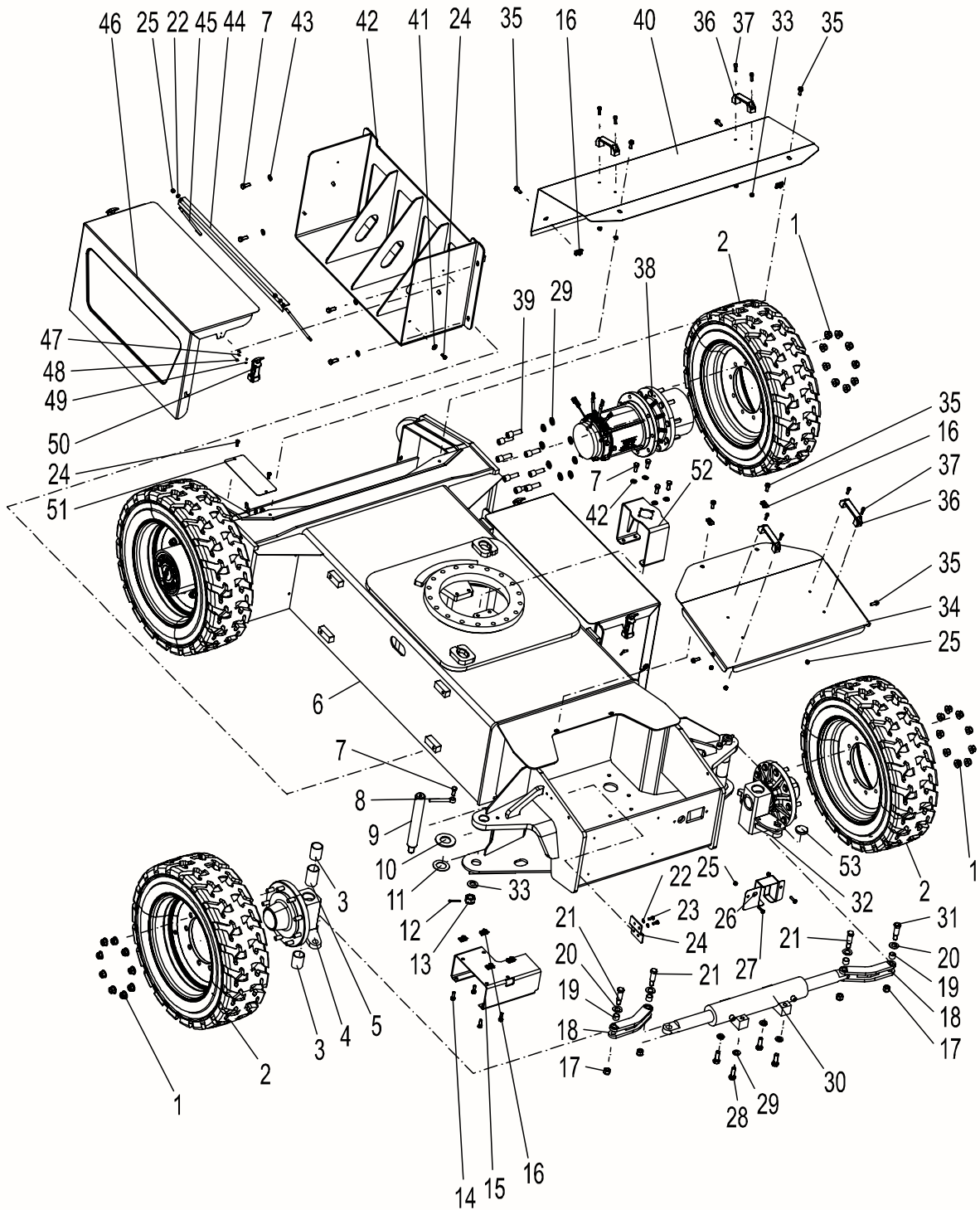

CHASSIS

Chassis 0077340282000000

NO.	Material No.	Item and Spec	Qty	Remark
33	1040301511	Gasket 24-200HV	2	GB/T97.1
34	00773402820001130	Front cover	1	
35	1040005831	Bolt M10×25-DKL	8	GB/T5789
36	1100700140	Solid handle	4	
37	1040103112	Screw M8×25-8.8	8	GB/T70.1
38	1030202344	Reducer motor assembly	2	
39	1040004649	Screw 5/8-11UNC×45-10.9	16	ANSIB18.3
40	00773402820001140	Rear cover	1	
41	1040302480	Gasket 8-200HV	4	GB/T96.1
42	00773402821010000	Battery box weldment	2	
43	1040302490	Gasket 12-200HV	12	GB/T97.1
44	00773402821001010	Battery fixed rod	2	
45	00773402821001020	Battery fixed rod	4	
46	00773402821020000	Battery box cover	2	
47	1040003254	Bolt M3×8-8.8	8	GB/T5783
48	1040200076	Nut M3-8	8	GB/T6170
49	1040100432	Screw M5×6-4.8	4	GB/T818
50	1109800045	Rubber zipper	4	
51	00773402820001160	Bottom cover plate	2	
52	00773402822400000	Support weldment	1	
53	00773402820001060	Angle sensor protective hood	4	
54	1089900652	Seal strip	7	
55	1990300401	U type tape	1	
56	204060296	Gear oil	4	

ZOOMLION

Parts Manual

Section 5 Power System



Power System Assembly 0077340711000000

5-1

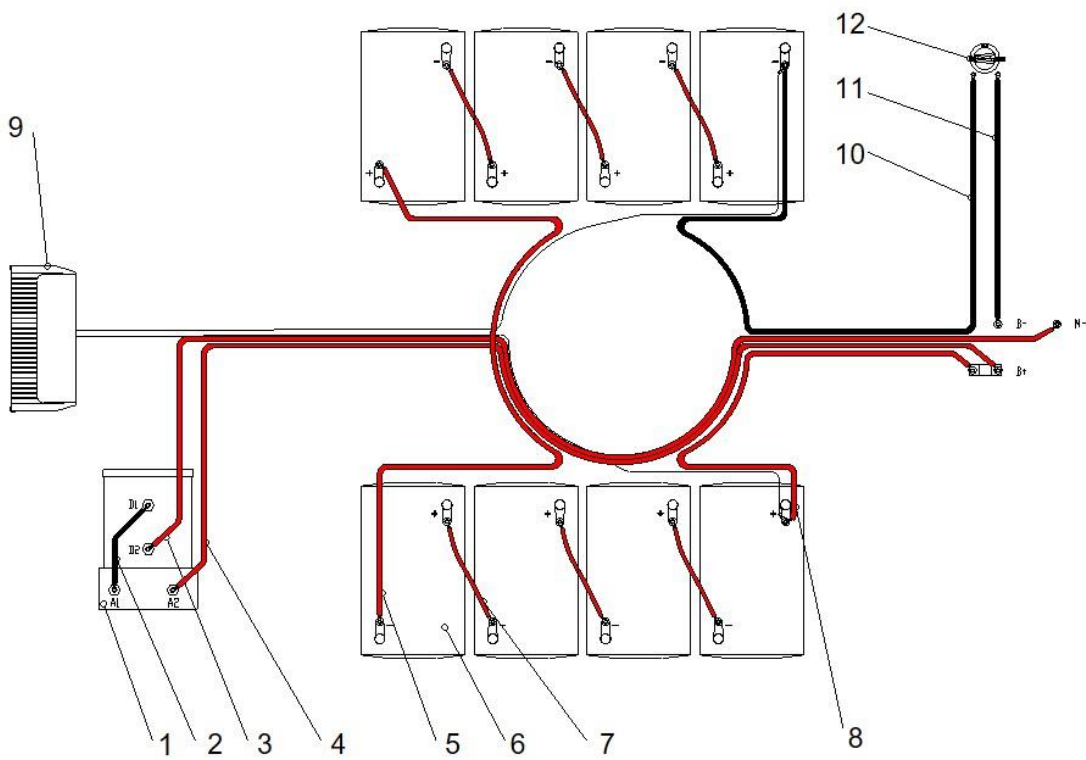

POWER SYSTEM

Power System Assembly 0077340711000000

No.	Material No.	Item and Spec	Qty	Remark
1	1020005380	DC motor	1	
2	00773406230450090	Wires (D1 to A1)	1	
3	00773406230450070	Wires (M-to D2)	1	
4	00773406230450060	Wires (B+to A2)	1	
5	00773406230450020	Series wires	1	
6	1020903378	Battery	8	
7	00773406230450010	Series wires	6	
8	00773406230450030	Insurance wires	1	
9	1020903393	Charger	1	
10	00773406230450040	Wires	1	
11	00773406230450050	Wires	1	
12	1029900667	Main power switch (knob)	1	

ZOOMLION

Parts Manual

Section 6 Hydraulic System



Hydraulic Tank Assembly 00773405210200000

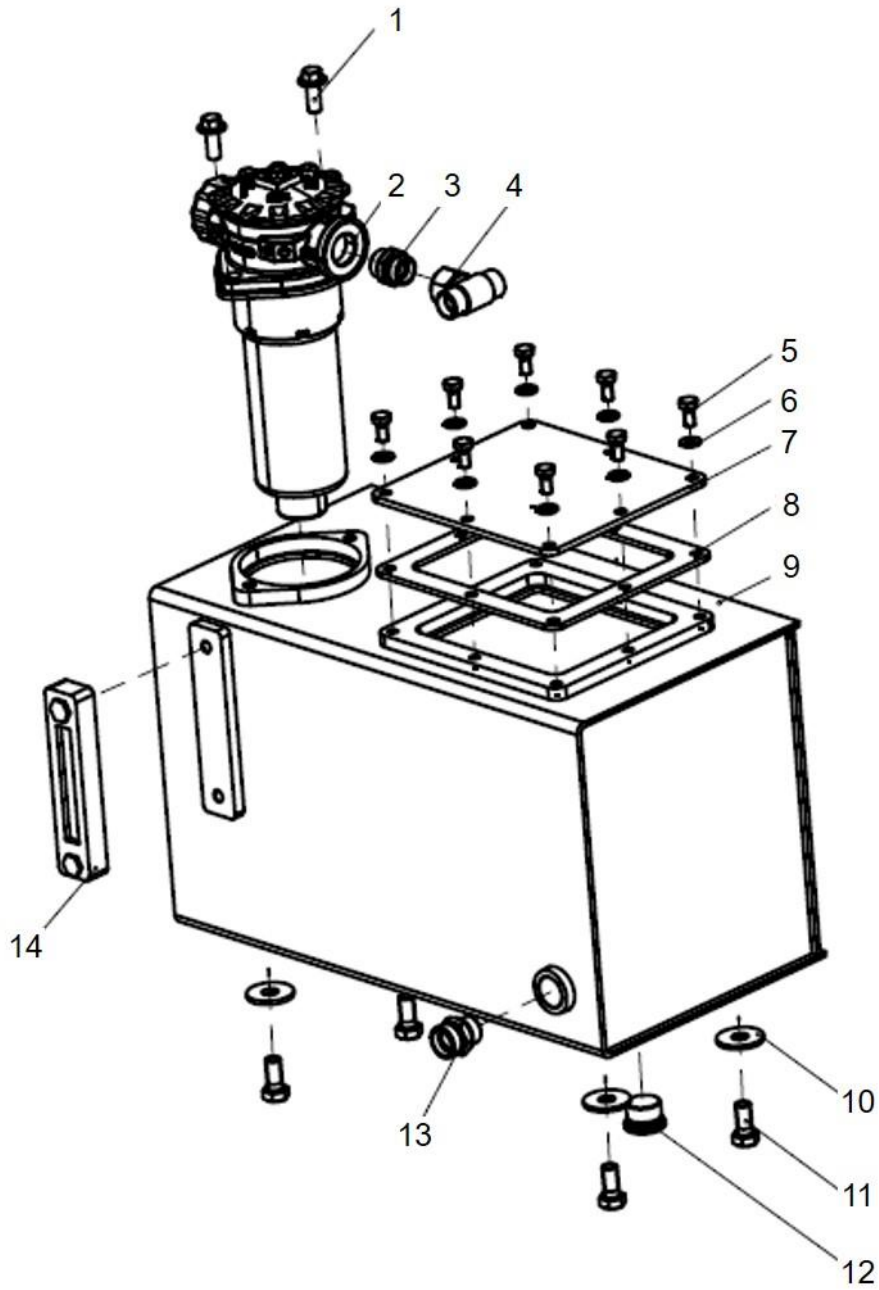

Hydraulic Tank Assembly 00773405210200000

NO.	Material No.	Item and Spec	Qty	Remark
1	1040005851	Screw M10×25-8.8	2	GB/T5787
2	1010601202	Return oil filter	1	
3	1140107825	Joint	1	
4	1140101484	Joint	1	
5	1040004517	Bolt M8×16-8.8	8	GB/T5783
6	1040301515	Gasket 8	8	GB/T97.1
7	00773405210220000	Cover	1	
8	00773405210230000	Sealing plate	1	
9	00773405210210000	Tank	1	
10	1040302821	Gasket 12	4	GB/T96.1
11	1040002436	Bolt M12×25-8.8	4	GB/T5783
12	1140101628	Plug screw	1	
13	1140101466	Joint	1	
14	1019901470	Liquid indicator	1	

Hydraulic Pump Assembly 0077340521040000

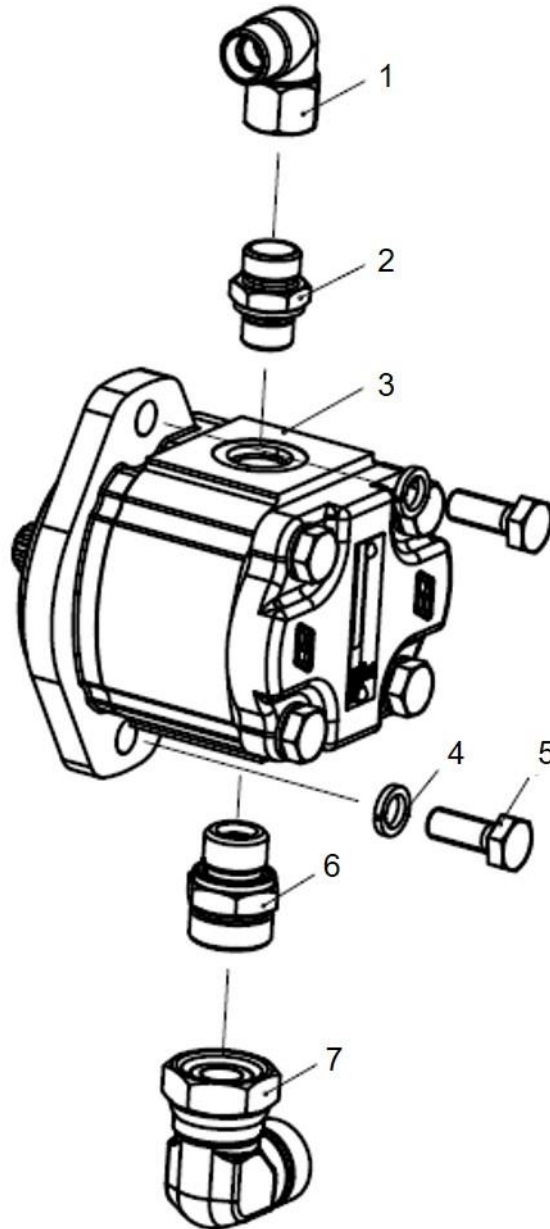

Hydraulic Pump Assembly 00773405210400000

NO.	Material No.	Item and Spec	Qty	Remark
1	1140101477	Joint	1	
2	1140114035	Joint	1	
3	1010002077	Gear pump	1	
4	1040301502	Gasket 10	2	GB/T93
5	1040002434	Bolt M10×25-8.8	2	GB/T5783
6	1140114034	Joint	1	
7	1140101479	Joint	1	

Steering Valve Assembly 0077340521060000

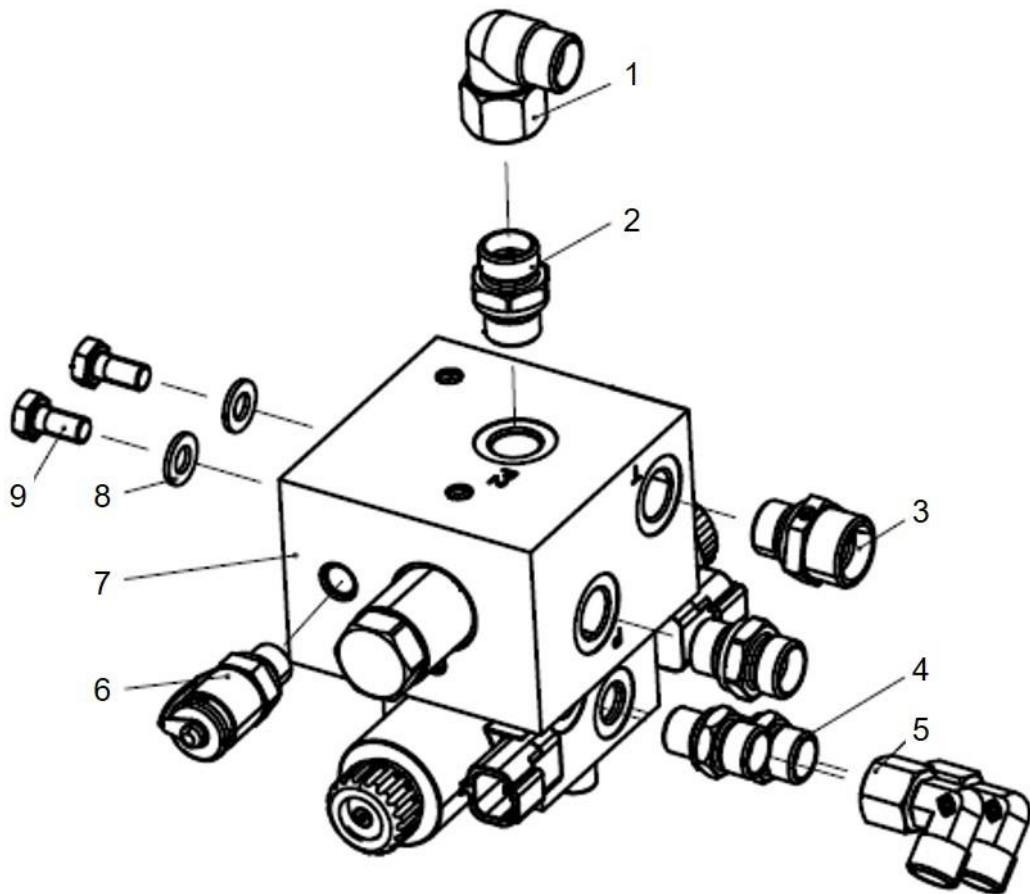

Steering Valve Assembly 0077340521060000

NO.	Material No.	Item and Spec	Qty	Remark
1	1140101477	Joint	1	
2	1140114036	Joint	2	
3	1140101465	Joint	1	
4	1140101461	Joint	2	
5	1140101476	Joint	2	
6	1140114187	Pressure test joint	1	
7	1010306615	Steering valve	1	
8	1040301515	Gasket 8	2	GB/T97.1
9	1040004517	Bolt M8×16-8.8	2	GB/T5783

Centre Revolving Joint Assembly 0077340521080000

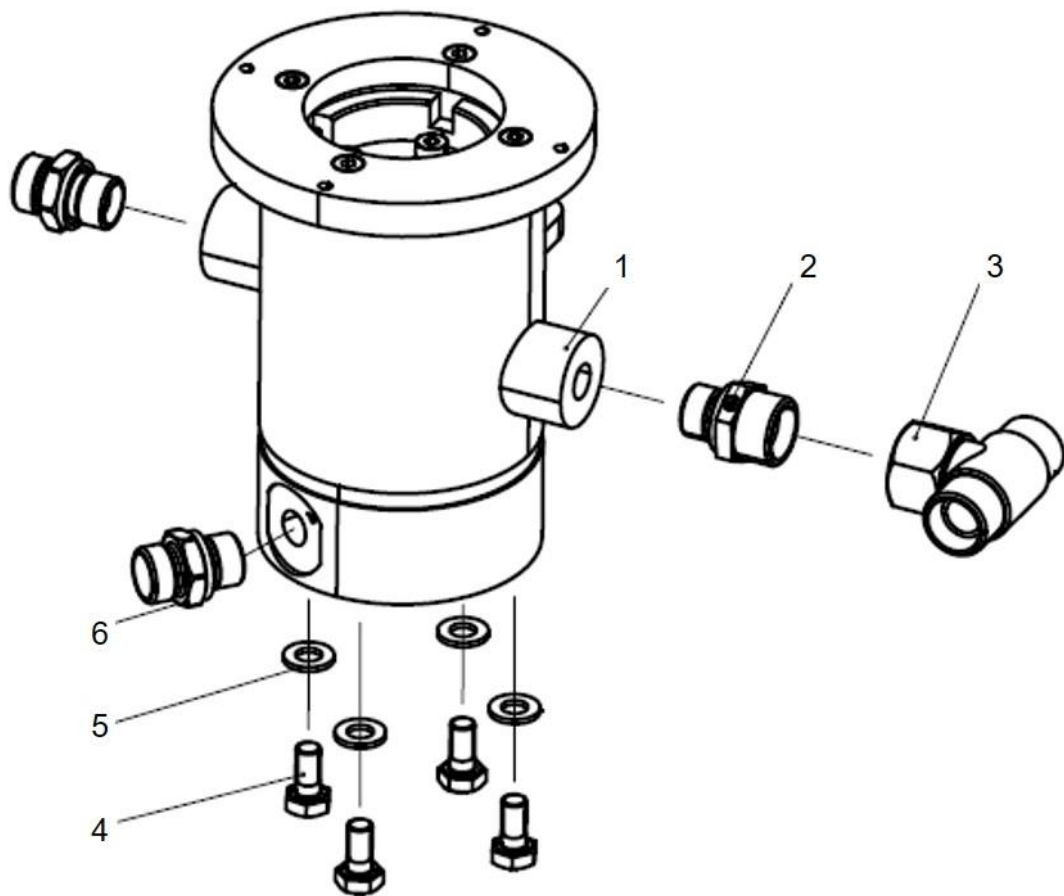

Centre Revolving Joint Assembly 0077340521080000

NO.	Material No.	Item and Spec	Qty	Remark
1	1011200181	Centre revolving joint	1	
2	1140101465	Joint	2	
3	1140101484	Joint	1	
4	1040004517	Bolt M8×16-8.8	4	GB/T5783
5	1040301515	Gasket 8	4	GB/T97.1
6	1140114036	Joint	2	

High Pressure Filter Assembly 0077340521100000

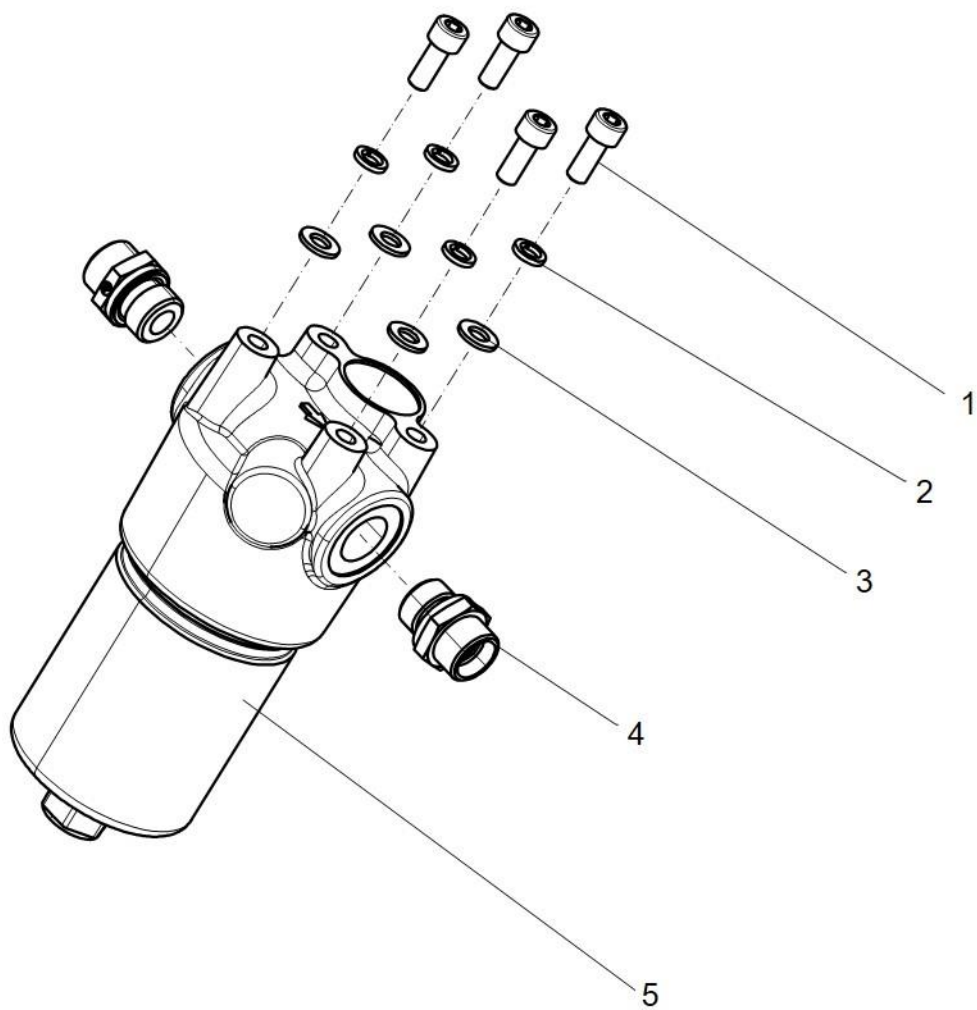

High Pressure Filter Assembly 0077340521100000

NO.	Material No.	Item and Spec	Qty	Remark
1	1040100069	ScrewM8×20-8.8	4	GB/T70.1
2	1040301510	Gasket 8	4	GB/T93
3	1040301515	Gasket 8-200HV	4	GB/T97.1
4	1140107481	Joint	2	
5	1010601138	High pressure filter	1	

Platform Select Valve Assembly 00773405211200000

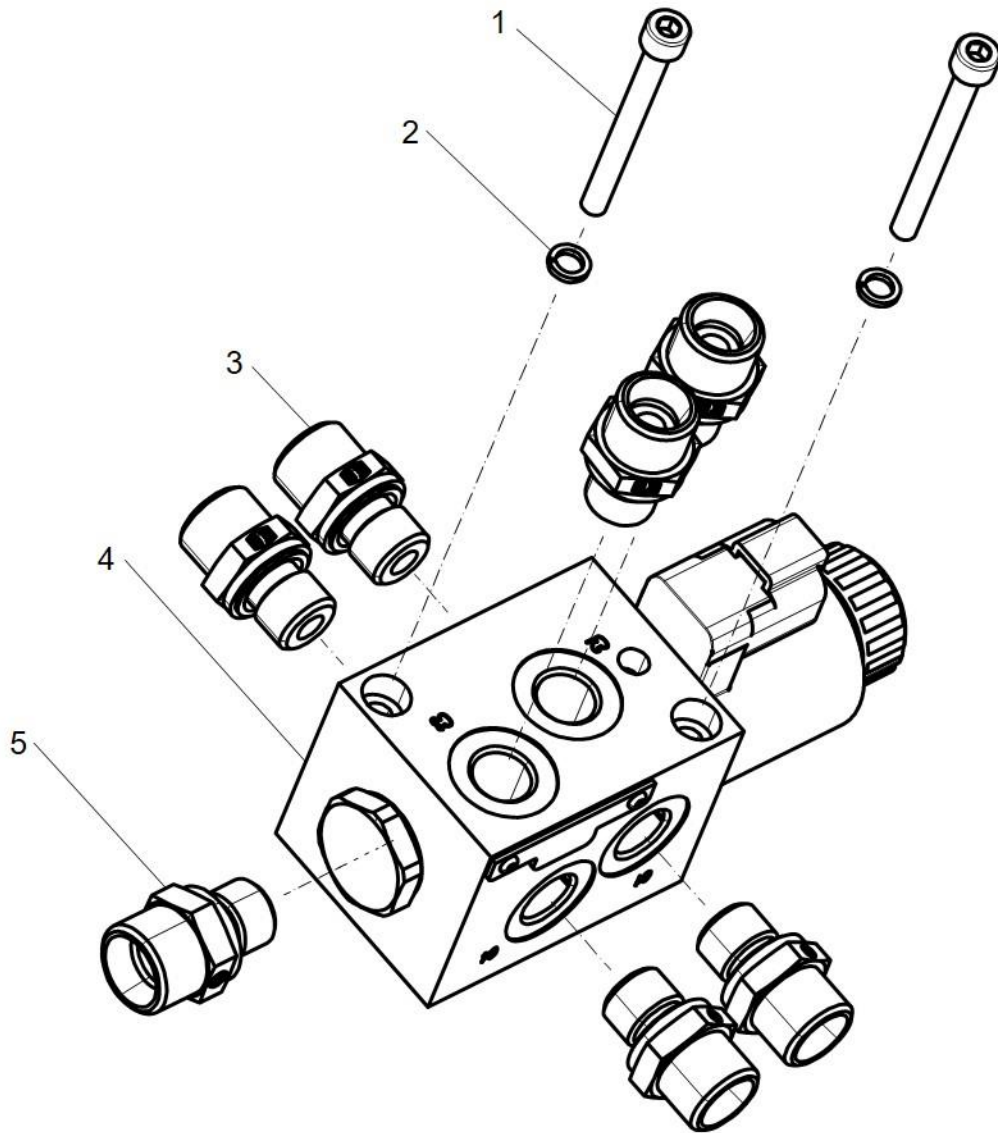

Platform Select Valve Assembly 00773405211200000

NO.	Material No.	Item and Spec	Qty	Remark
1	1040102777	ScrewM4×50-8.8	2	GB/T70.1
2	1040300060	Gasket 5	2	GB/T93
3	1140101461	Joint	6	
4	1010306226	Direction valve	1	
5	1019807649	Check valve	1	

Main Valve Assembly 00773405211600000

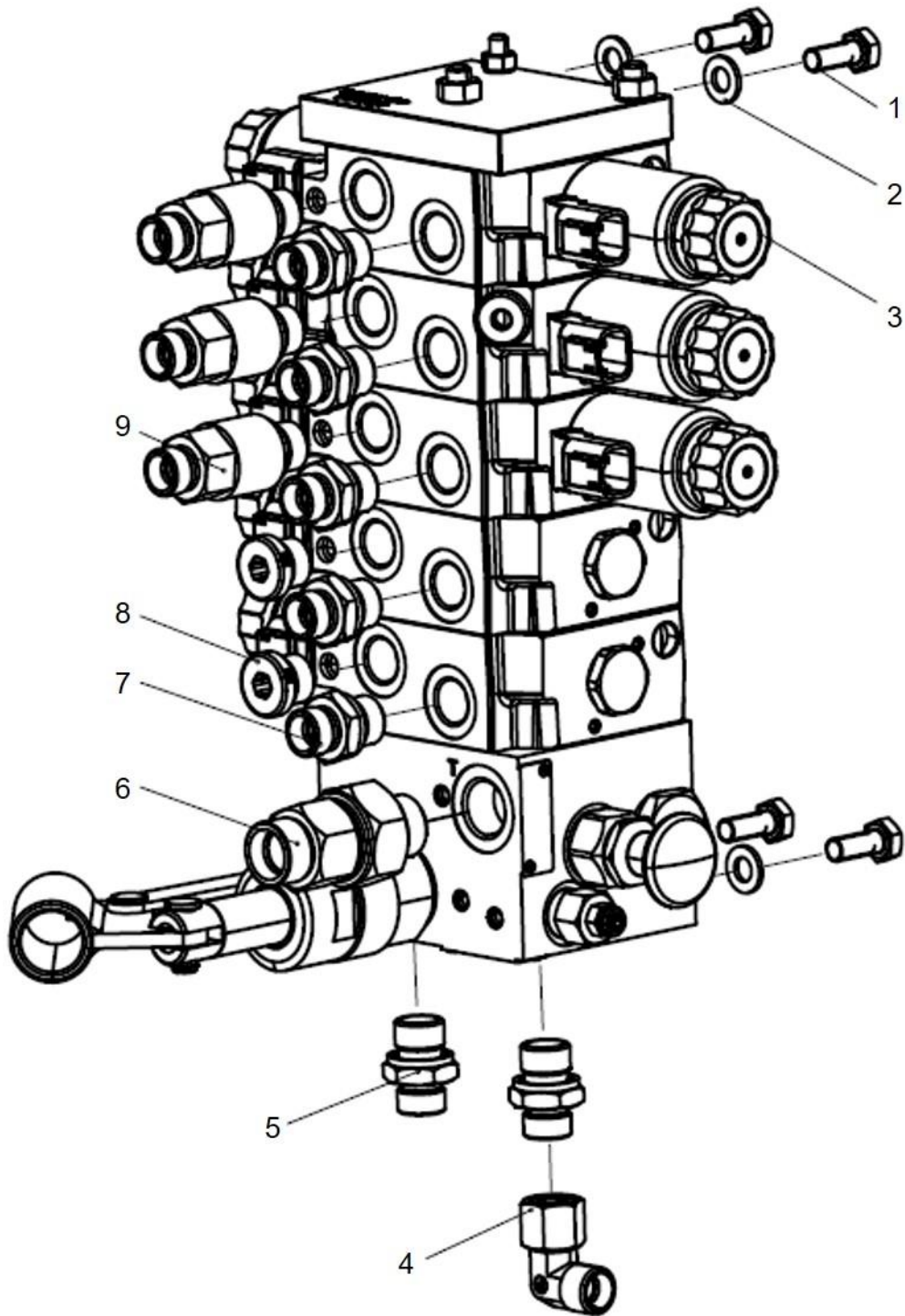

Main Valve Assembly 00773405211600000

NO.	Material No.	Item and Spec	Qty	Remark
1	1040004518	Bolt M8×20-8.8	4	GB/T5783
2	1040301515	Gasket 8	4	GB/T97.1
3	1010306614	Main Valve	1	
4	1140101476	Joint	1	
5	1140114036	Joint	1	
6	1010302829	Check valve	1	
7	1140114040	Joint	6	
8	1140101629	Plug screw	2	
9	1140114625	Joint	3	

Telescopic Select Valve Assembly 0077340521240000

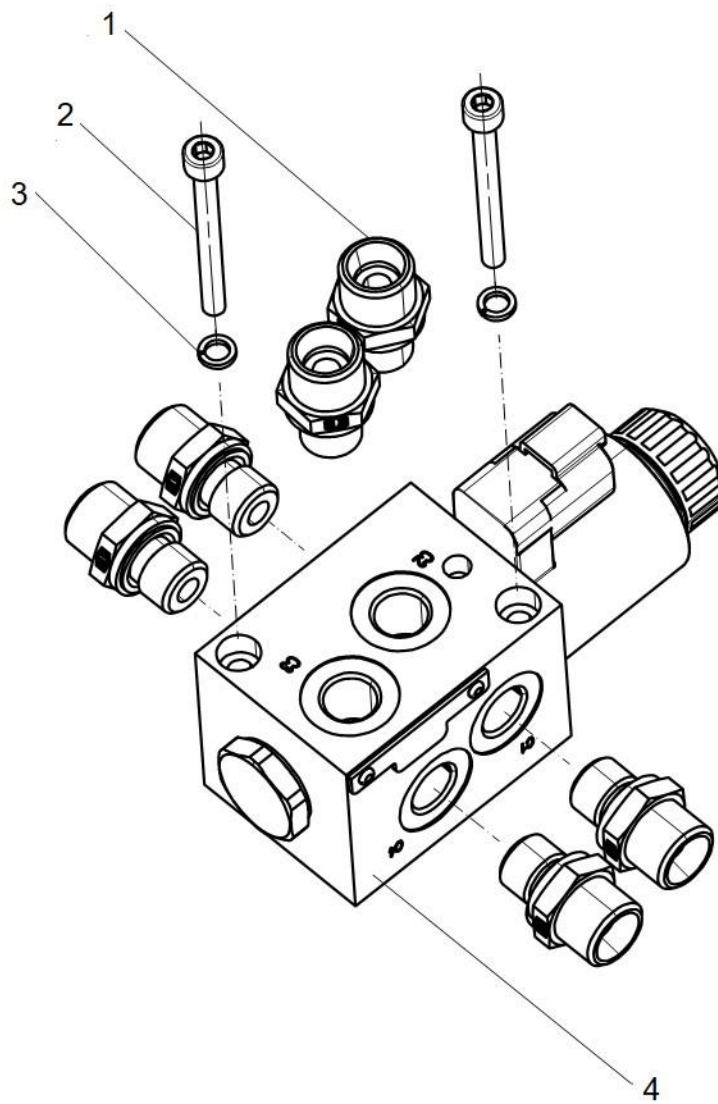

Telescopic Select Valve Assembly 00773405212400000

NO.	Material No.	Item and Spec	Qty	Remark
1	1140101461	Joint	6	
2	1040103107	ScrewM5×45-8.8	2	GB/T70.1
3	1040300060	Gasket 5	2	GB/T93
4	1010306016	Platform select valve	1	

Balance Valve Assembly 0077340521280000

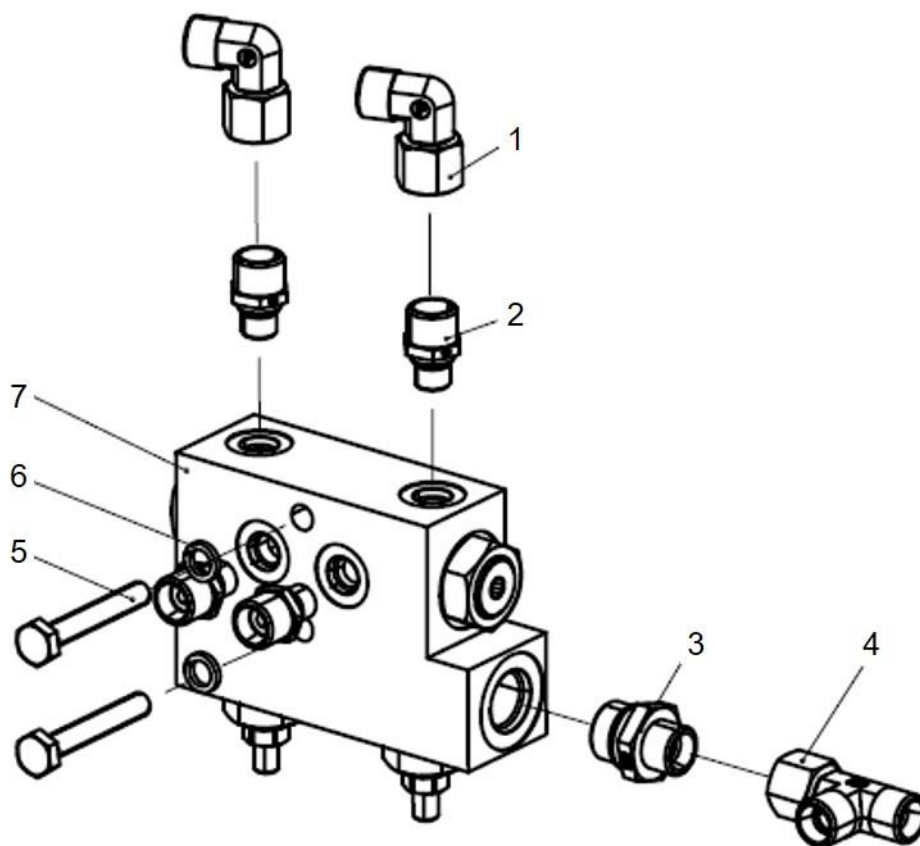

Balance Valve Assembly 00773405212800000

NO.	Material No.	Item and Spec	Qty	Remark
1	1140101476	Joint	2	
2	1140112827	Joint	4	
3	1140112820	Joint	1	
4	1140114046	Joint	1	
5	1040004522	Bolt M8×50-8.8	2	GB/T5783
6	1040301510	Gasket 8	2	GB/T93
7	1010306368	Cylinder control valve	1	

Balance Valve Assembly 00773405213000000

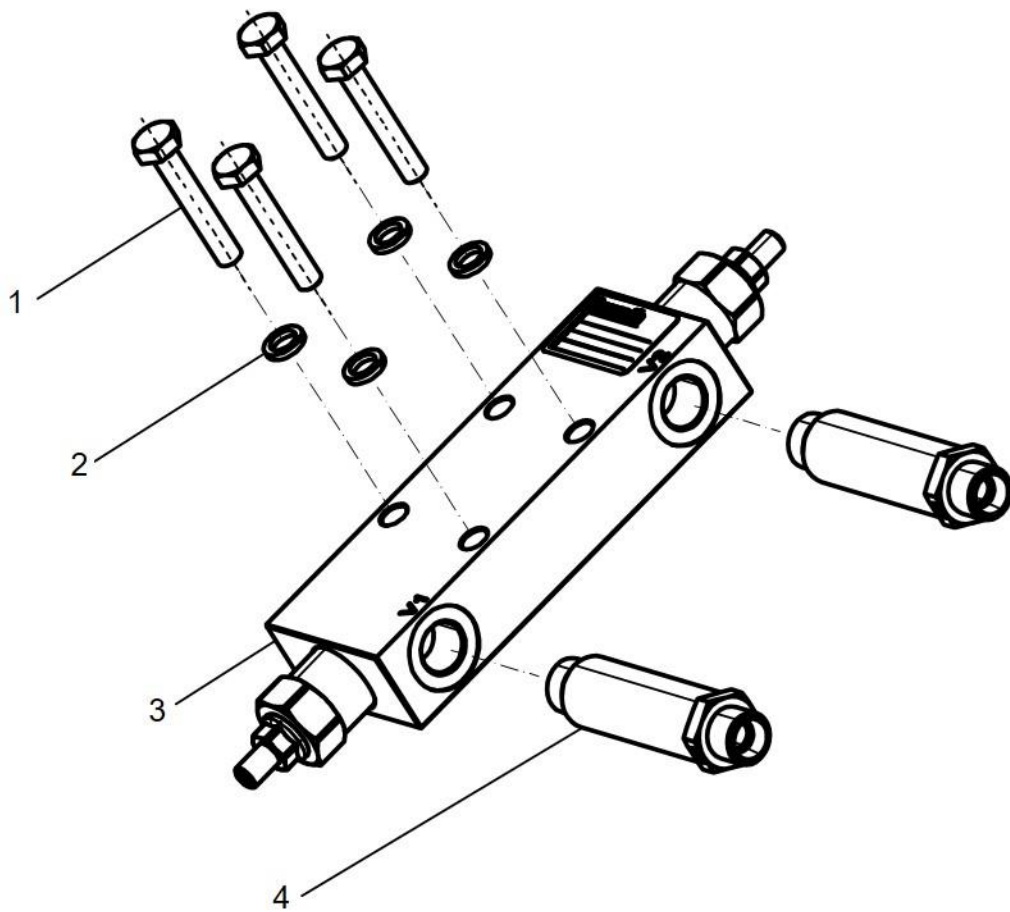

Balance Valve Assembly 00773405213000000

NO.	Material No.	Item and Spec	Qty	Remark
1	1040004521	Bolt M8×45-8.8	4	GB/T5783
2	1040301510	Gasket 8	4	GB/T93
3	1010306020	Balance valve	1	
4	1140114624	Joint	2	

Balance Valve Assembly 00773405213200000

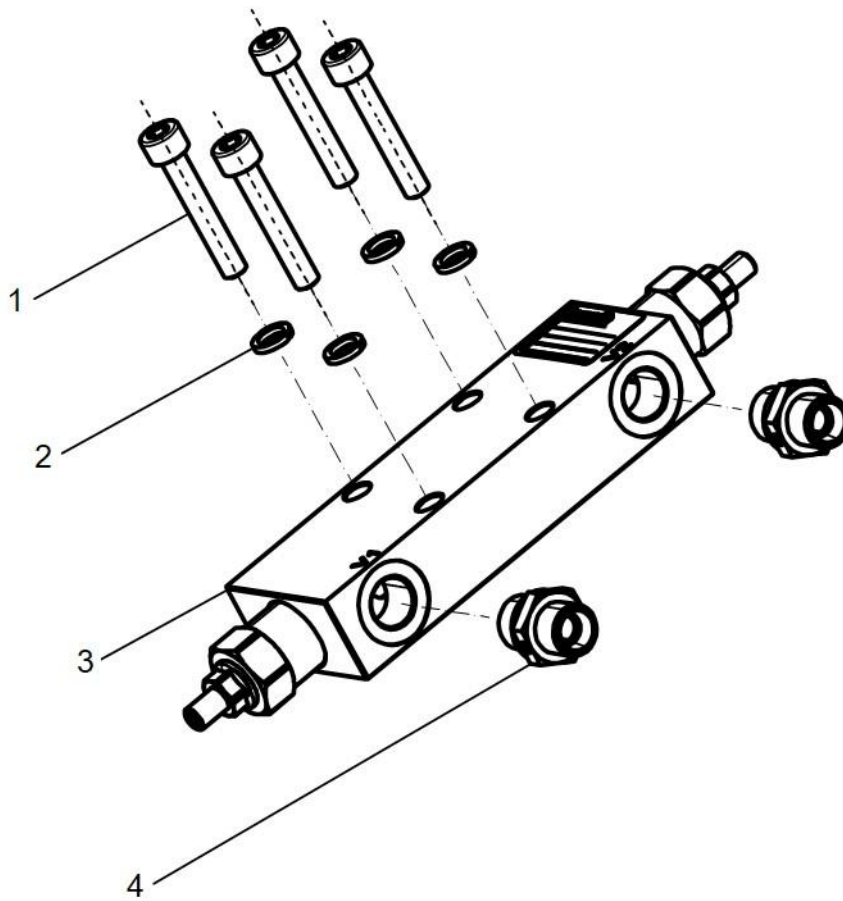

Balance Valve Assembly 00773405213200000

NO.	Material No.	Item and Spec	Qty	Remark
1	1040100148	Screw M8×45-8.8	4	GB/T5783
2	1040301510	Gasket 8	4	GB/T93
3	1010306020	Balance valve	1	
4	1140114040	Joint	2	

Balance Valve Assembly 0077340521340000

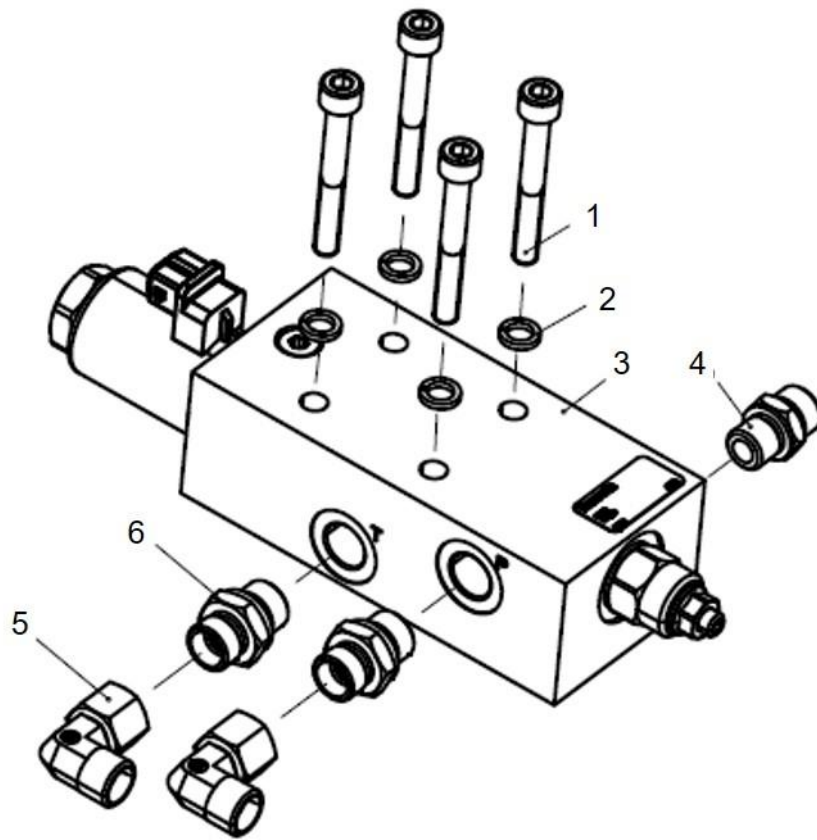

Balance Valve Assembly 00773405213400000

NO.	Material No.	Item and Spec	Qty	Remark
1	1040102739	Screw M8×60-8.8	4	GB/T70.1
2	1040301510	Gasket 8	4	GB/T93
3	1010306616	Lifting balance valve	1	
4	1140101461	Joint	1	
5	1140101476	Joint	2	
6	1140114040	Joint	2	

Balance Valve Assembly 0077340521360000

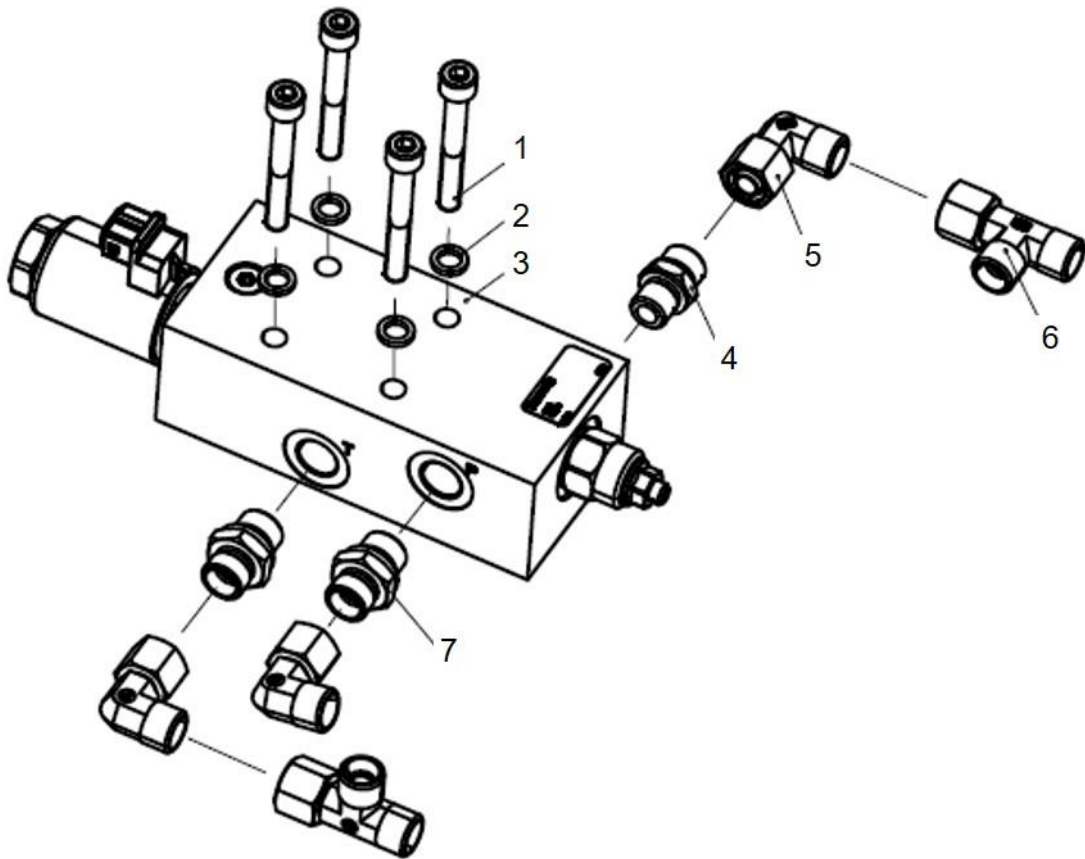

Balance Valve Assembly 00773405213600000

NO.	Material No.	Item and Spec	Qty	Remark
1	1040102739	Screw M8×60-8.8	4	GB/T70.1
2	1040301510	Gasket 8	4	GB/T93
3	1010306616	Lifting balance valve	1	
4	1140101461	Joint	1	
5	1140101476	Joint	3	
6	1140114046	Joint	2	
7	1140114040	Joint	2	

Balance Valve Assembly 0077340521380000

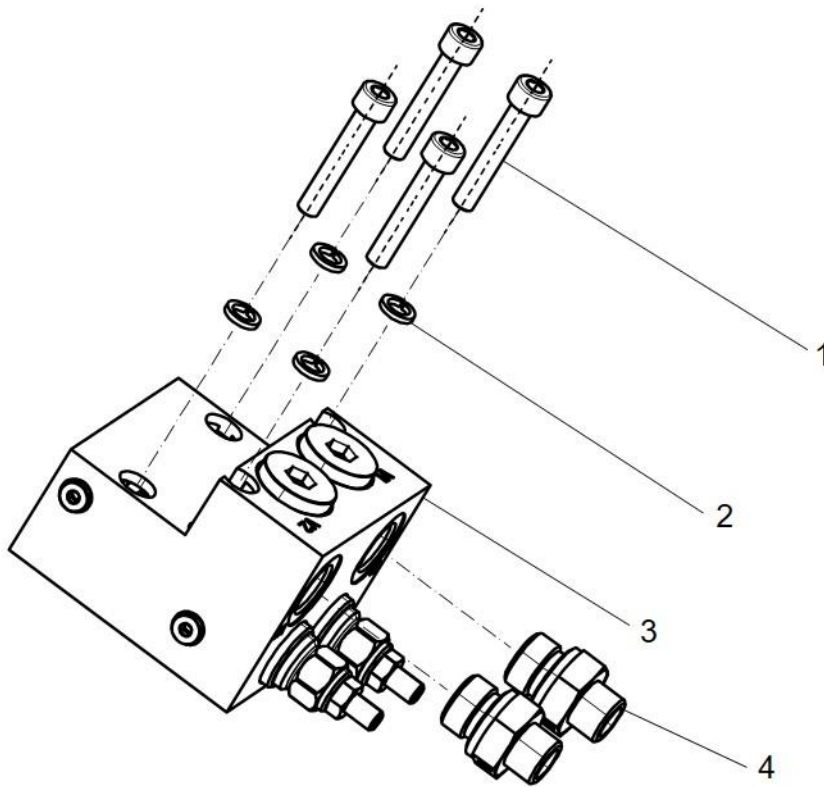

Balance Valve Assembly 00773405213800000

NO.	Material No.	Item and Spec	Qty	Remark
1	1040100148	ScrewM8×45-8.8	4	GB/T70.1
2	1040301510	Gasket 8	4	GB/T93
3	1010306060	Telescopic balance valve	1	
4	1140102936	Joint	2	

Hydraulic System Piping Diagram 0077340521400000

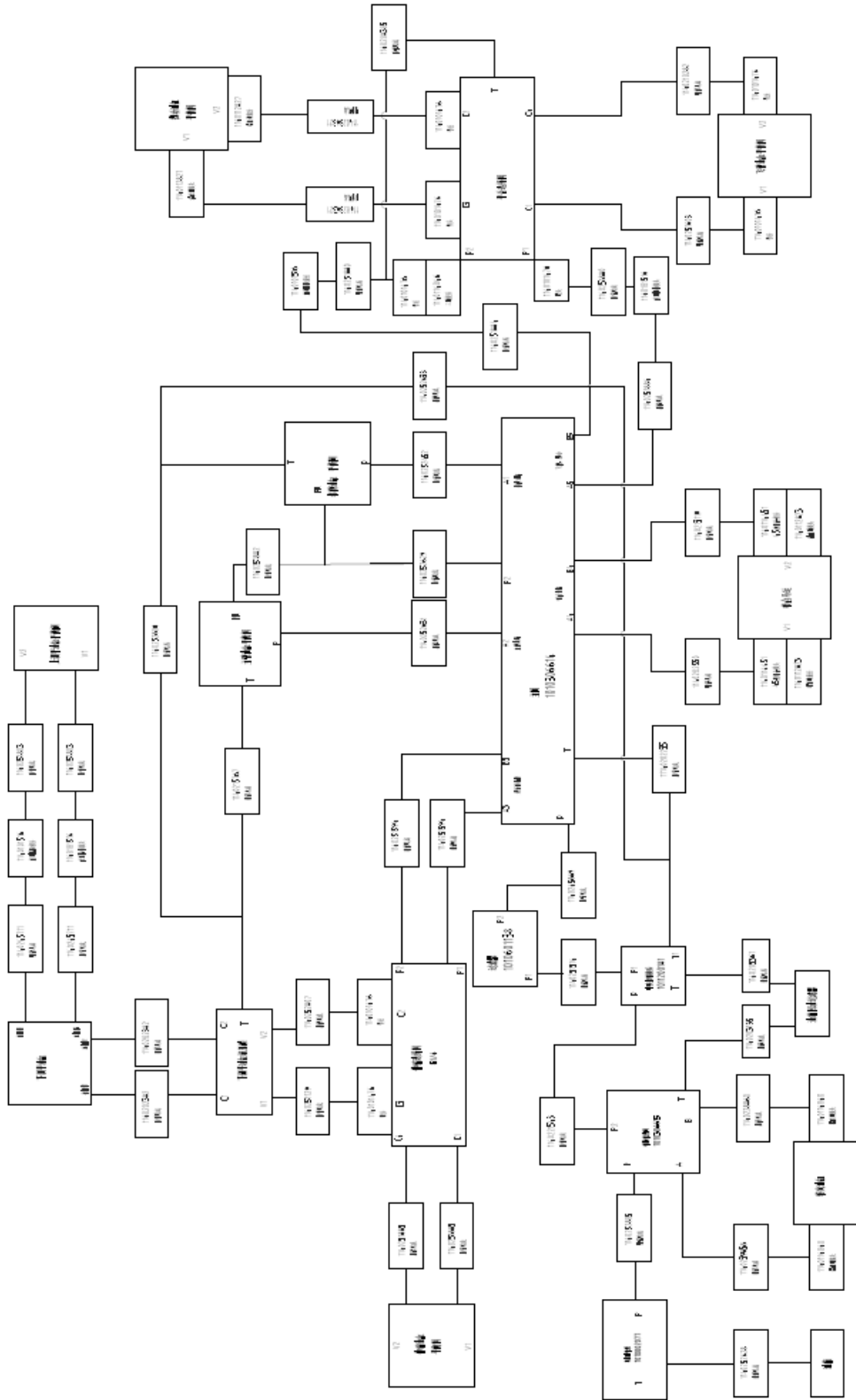

HYDRAULIC SYSTEM

ZOOMLION

Parts Manual

Section 7 Electrical System



Turntable Electrical Control Box Assembly 00773406230220000

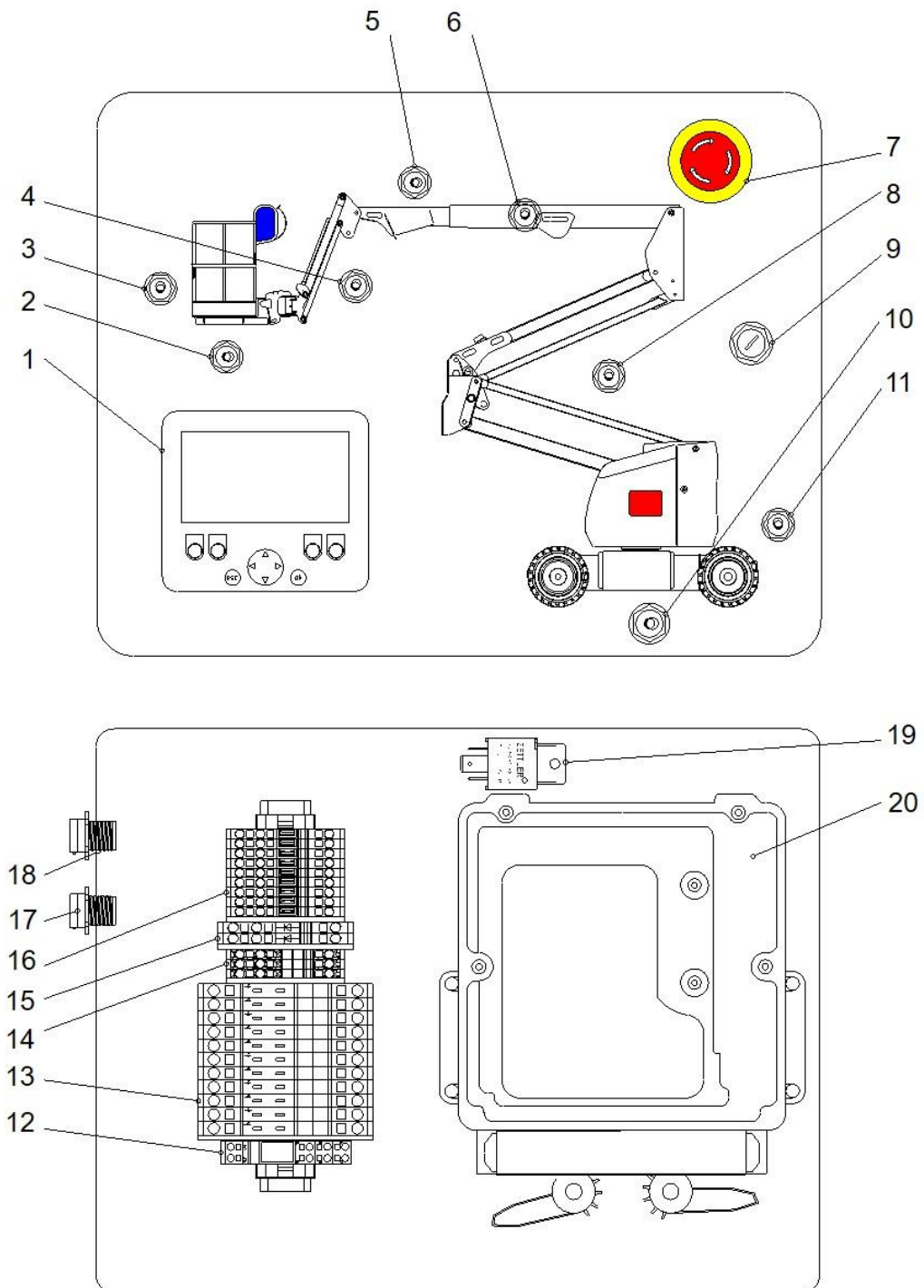

Turntable Electrical Control Box Assembly 00773406230220000

NO.	Material No.	Item and Spec	Qty	Remark
1	1020201651	Display	1	
2	1020520084	Toggle switch	1	Platform rotary
3	1020520084	Toggle switch	1	Platform leveling
4	1020520084	Toggle switch	1	Jib lift
5	1020520084	Toggle switch	1	Boom telescopic
6	1020520084	Toggle switch	1	Boom lift
7	1020519658	Emergency button	1	Emergency switch
	1020509007	Button seat	1	
8	1020520084	Toggle switch	1	Tower boom lift
9	1020520943	Key switch	1	
10	1020520084	Toggle switch	1	Turntable rotary
11	1020520084	Toggle switch	1	Emergency power and enable
12	1020304559	Relay	1	Light relay
13	1020604934	Terminal	11	
14	1020704265	Grounding terminal strip	3	
15	1020705826	Terminal	2	
16	1029904980	Terminal	9	
17	1029903317	48 core sheath	1	Turntable cable
18	1029902634	32 core sheath	1	Turntable cable
19	1020304584	Power relay	1	
20	1020103903	Controller	1	
	1020103955	Connector assembly	1	

Platform Electrical Box Assembly 00773406230210000

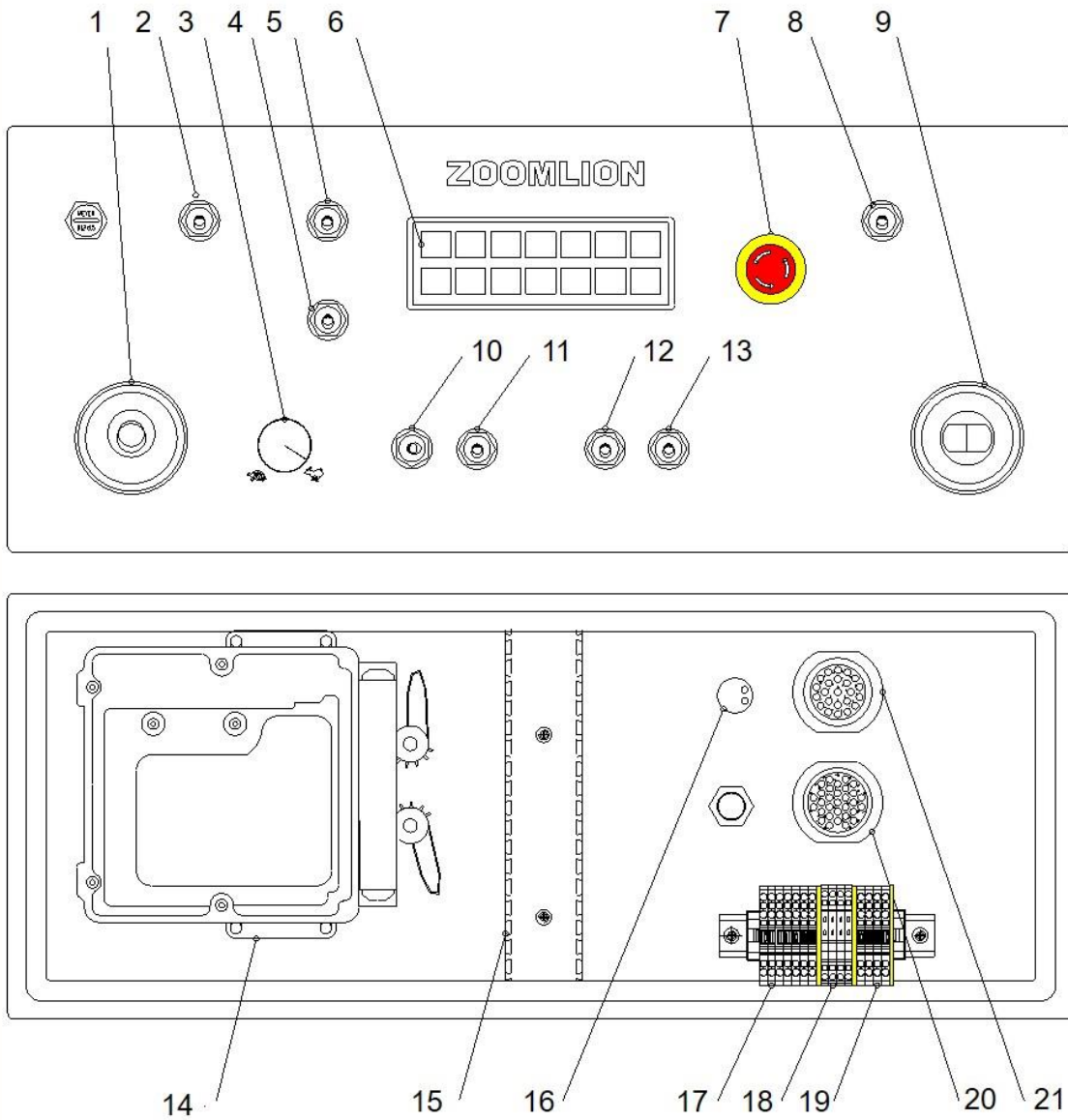

Platform Electrical Box Assembly 00773406230210000

NO.	Material No.	Item and Spec	Qty	Remark
1	1020520994	Handle	1	
2	1020520083	Toggle switch	1	Directional drive
3	1020520995	Potentiometer	1	
4	1020520136	Toggle switch	1	Lighting
5	1020520135	Toggle switch	1	Travel speed control
6	1020405061	Indicator panel	1	
7	1020519658	Emergency button	1	
	1020509007	Button seat	1	
8	1020520135	Toggle switch	1	Platform leveling control
9	1020520993	Handle	1	
10	1020520084	Toggle switch	1	Platform rotary switch
11	1020520084	Toggle switch	1	Jib lift switch
12	1020520084	Toggle switch	1	Tower boom lift
13	1020520084	Toggle switch	1	Jib telescopic
14	1020103903	Controller	1	
	1020103955	Connector assembly	1	
15	1022399012	Wiring Duct	1	
16	1020404405	Flash buzzer	1	
17	1029904980	Terminal	7	
18	1029905392	Terminal	4	
19	1020704265	Grounding terminal strip	4	
20	1020703394	Deutsch connector	1	Chain-electrical wires
21	1020703393	Round plug	1	Platform-electrical wires

Turntable cable 00773406230410000

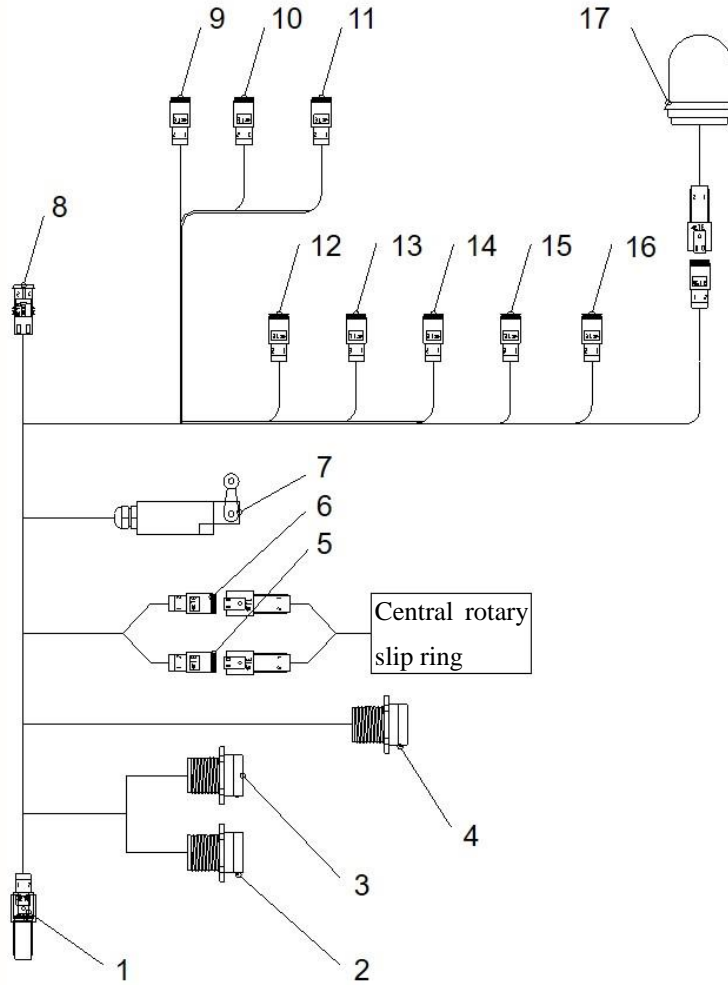

Turntable cable 00773406230410000

NO.	Material No.	Item and Spec	Qty	Remark
1	/	Road Lighting	/	
2	1029903316	Sheath	1	Electrical box
	1029902632	Terminal	44	
3	1029902635	Sheath	1	Electrical box
	1029902630	Terminal	2	
4	1020703394	Round plug	1	Boom wires
	1020700969	Terminal	26	
5	1020703391	Sheath	1	Slip ring plug-in 1
	1020700957	Sheath	1	Plug-in
6	1020700440	Sheath	1	Slip ring plug-in 2
	1020700942	Sheath	1	Plug-in
7	1020516032	Steering angle limit switch	1	
8	1020304982	Buzzer	1	
9	1020700951	/	1	Telescopic reversing valve 2
10	1020700951	/	1	Turntable right turn valve 2
11	1020700951	/	1	Jib reversing valve 1
12	1020700951	/	1	Tower boom lifting valve
13	1020700951	/	1	Main boom lifting valve
14	1020700951	/	1	Telescopic reversing valve 1
15	1020700951	/	1	Turntable left turn valve
16	1020700951	/	1	Reversing valve 2
17	1020404399	Warning light	1	

Boom Wires 00773406230430000

00773406230430000

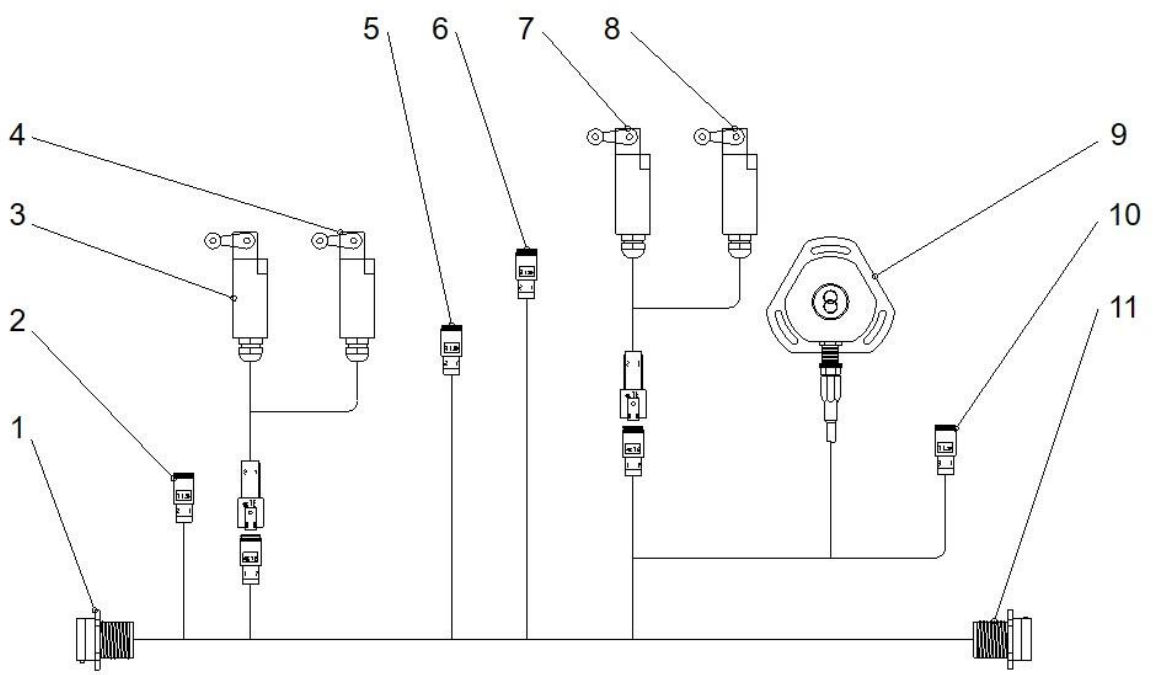

Boom wires 00773406230430000

NO.	Material No.	Item and Spec	Qty	Remark
1	1029903711	Connector	1	
2	1020700951	Connector	1	
3	1020516032	Tower boom angle limit switch 1	1	
4	1020516032	Tower boom angle limit switch 2	1	
5	1020700951	Connector	1	
6	1020700951	Connector	1	
7	1020516032	Boom length limit switch 1	1	
8	1020516032	Boom length limit switch 2	1	
9	1021404019	Boom leveling angle sensor	1	
10	1020700540	Terminal resistance	1	
11	1020703394	Connector	1	

Chassis Wires 00773406230420000

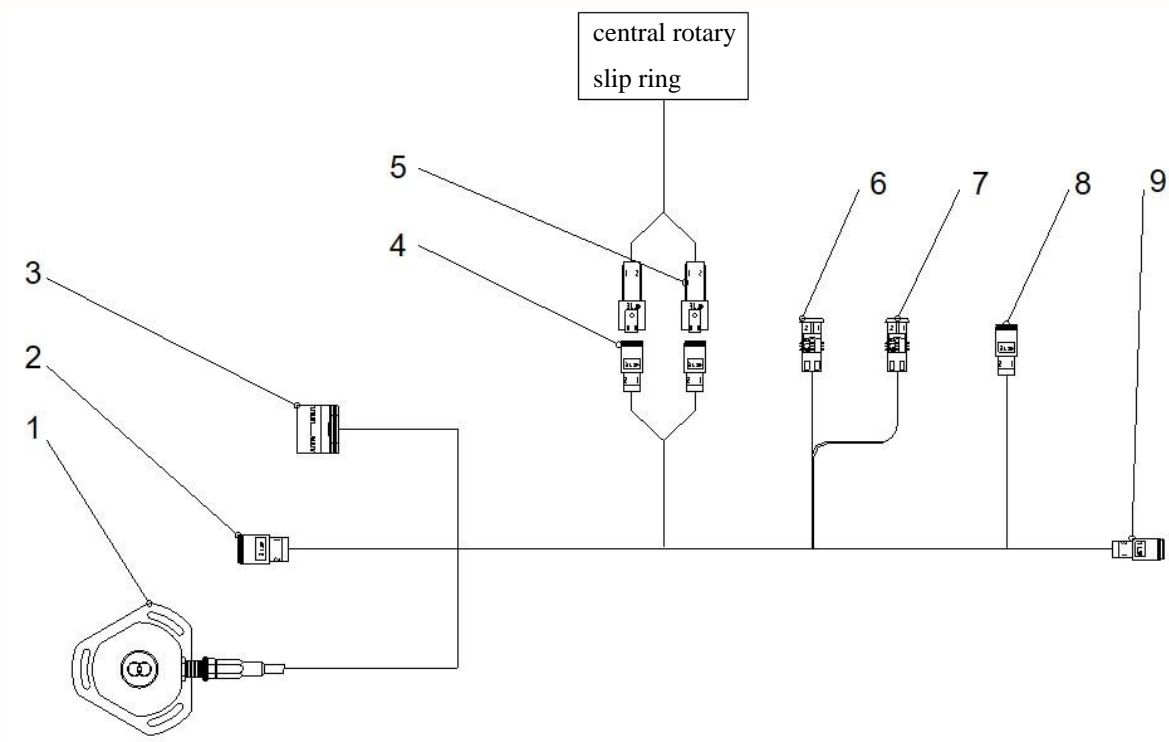

Chassis Wires 00773406230420000

NO.	Material No.	Item and Spec	Qty	Remark
1	1021404018	Body angle sensor	1	
2	1020700957	Sheath	1	
3	1020702062	Sheath	1	
4	1020703391	Sheath	1	Slip ring plug-in 1
	1020700957	Sheath	1	Plug-in
5	1020700440	Sheath	1	Slip ring plug-in 2
	1020700942	Sheath	1	Plug-in
6	1029900318	Sheath	1	Left turn valve
7	1029900318	Sheath	1	Right turn valve
8	1020700951	Sheath	1	Charger
9	1029900385	Sheath	1	Steering angle sensor

Platform Wires 00773406230440000
Chain Wires Change 00773406230610000

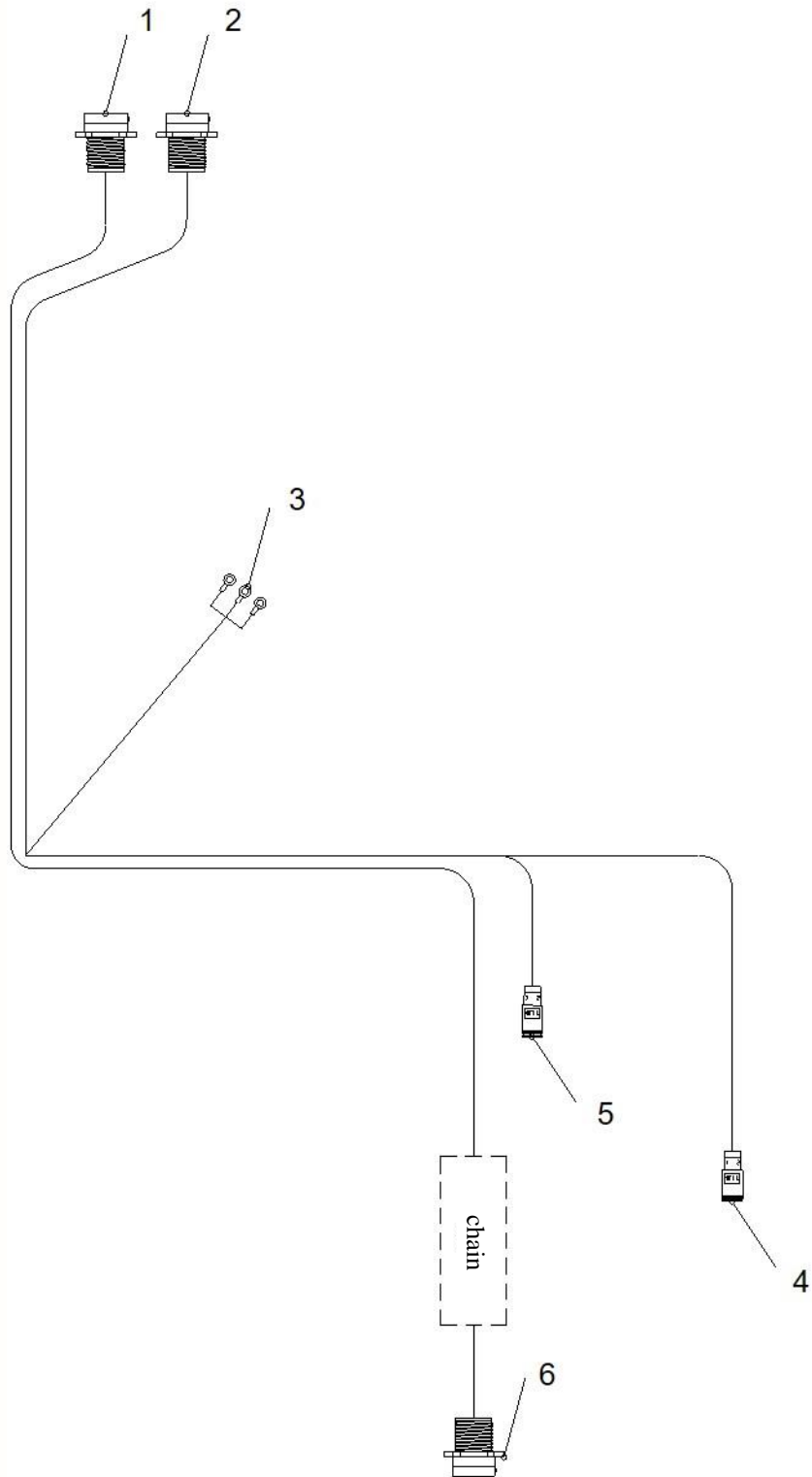

00773406230440000

Platform Wires 00773406230440000
Chain Wires Change 00773406230610000

NO.	Material No.	Item and Spec	Qty	Remark
1	1029903711	Sheath	1	Chain plug-in
2	1022200446	Sheath	1	Platform connector
3	1020521022	Foot Switch	1	
4	1020700951	Sheath	1	Jib lifting select valve
5	1021404016	Load Cell	1	
6	1029903711	Sheath	1	Chain plug-in

